

GASMAC

TECHNICAL SUPPORT: 1-800-403-3279

Installation / Operating Instructions for

GARAGEMAC

Infrared Radiant Tube Heater/Radiateur a tube rayonnant a infrarouge

A COPY OF THIS MANUAL MUST BE PROVIDED TO THE END USER

MODEL NUMBERS

GM-40U GM-40S

40,000 BTUH

LIQUID PROPANE OR NATURAL GAS

TECHNICAL DATA FOR STRAIGHT AND U CONFIGURED HEATERS



The installation must conform with local building codes or, in the absence of local codes, the *National Fuel Gas Code*, ANSI Z223.1/NFPA 54, or the *Natural Gas and Propane Installation Code*, CSA B149.1 The latest edition Electrical Code PART 1 CSA C22.1 in Canada and ANSI/NFPA NO 70 in the USA must also be observed.

It is beyond the scope of these instructions to consider all conditions that may be encountered.



WARNING: Improper installation, adjustment, alteration, service or maintenance can cause property damage, injury or death. Read the installation, operating and maintenance instructions thoroughly before installing or servicing this heater.



AVERTISSEMENT. Une installation, un réglage, une modification, une réparation ou un entretien incorrect peut entraîner des dommages matériels, des blessures ou la mort. Lisez attentivement les instructions d'installation, de fonctionnement et d'entretien avant de procéder à l'installation ou à l'entretien de cet radiateur.

APPLIANCE OVERVIEW

The Garagemac Shop/Garage heater is supplied with a region specific ½" flexible gas connector, a 24V thermostat, and a 4" OD side wall exhaust termination cap.

GM-40S

OVERALL LENGTH: 22' / 670 cm
OVERALL WIDTH: 13" / 33 cm
OVERALL DEPTH: 10" / 25 cm
WEIGHT: 90 lbs. / 41 kg.

BUILDING SPAN REQ: 25' / 762 cm
CEILING HEIGHT REQ: 8' / 244 cm

GM-40U

OVERALL LENGTH: 12' / 366 cm
OVERALL WIDTH: 22" / 66 cm
OVERALL DEPTH: 10" / 25 cm
WEIGHT: 90 lbs. / 41 kg.

BUILDING SPAN REQ: 15' / 457 cm
CEILING HEIGHT REQ: 8' / 244 cm

NOTE: Above appliance dimensions represent the maximum at any point in the appliance. Dimensions at certain points of the appliance may be less.



WARNING

THIS AND EVERY GAS FIRED PRODUCT MUST ONLY BE INSTALLED OR SERVICED BY A PROFESSIONALLY LICENSED AND QUALIFIED GAS TECHNICIAN. INSTALLING GAS FIRED APPLIANCES WITHOUT THE REQUISITE LICENCE, KNOWLEDGE AND/OR UNDERSTANDING OF ALL RELEVELANT CODES AND REQUIREMENTS CAN RESULT IN FIRE, EXPLOSION, PROPERTY DAMAGE, INJURY, DEATH, BE CONSTRUED AS NEGLIGENCE, AND/OR CAUSE THE CANCELLATION OF IN FORCE LOSS/LIABILITY INSURANCE COVERAGE.



ENSURE THAT ALL WARNINGS, NOTICES, AND INSTRUCTIONS IN THIS MANUAL ARE FULLY READ AND UNDERSTOOD BEFORE INSTALLING THIS APPLIANCE. IF UNCLEAR ON ANY PORTION OF THIS MANUAL, PLEASE CONTACT THE MANUFACTURER FOR CLARIFICATION PRIOR TO INSTALLATION.

**SAFETY ALERT**

Do not store or use gasoline or other flammable vapors and liquids in the vicinity of this or any other gas fired appliance.

ALERTE DE SÉCURITÉ

Ne pas stocker ou utiliser d'essence ou d'autres vapeurs et liquides inflammables à proximité de cet appareil ou d'un autre appareil à gaz

**FOR YOUR SAFETY
IF YOU SMELL GAS**

1. Open windows
2. Do not touch electrical switches, or telephone
3. Extinguish any open flame
4. Immediately call your fuel supplier from a neighbor's phone
5. If your gas supplier is not available, call the fire department
6. Do not attempt to light this or any other appliance

**Consignes De Securite
SI VOUS SENTEZ UNE ODEUR DE GAZ**

1. Ouvrez les fenetres
2. Ne touchez pas aux interrupteurs electriques
3. Eteignez toute flamme nue
4. Contactez immediatement compagnie de gaz
5. Si votre fournisseur de gaz n'est pas disponible, appeler les pompiers.
6. Ne pas tenter d'allumer ceci ou aucun autre appareil.

**WARNING**

This appliance may have sharp edges and corners. Wear protective clothing such as gloves and protective eye wear when servicing this or any other appliance

ATTENTION

Cet appareil peut avoir des arêtes vives et des coins. Porter des vêtements de protection tels que des gants et des lunettes de protection lors de l'entretien de cet appareil ou de tout autre appareil.

For indoor installation only.
Not for use in residential dwellings.

Installation a l'interieur seulement. Ne pas utiliser pour le chauffage d'habitations

Gas Supply	N.G.	Propane	Electrical	
Manifold Pressure	3.5" W.C.	10.0" W.C.	120 volts 60Hz	
Min. Inlet Pressure	7.0" W.C.	11.5" W.C.	Starting Current	3 amps
Max. Inlet Pressure	14.0" W.C.	14.0" W.C.	Running Current	1 amp
Max. Outlet Pressure	3.5" W.C.	10.0" W.C.	Thermostat Control	120V (Standard)
Gas Connection	½ in. N.P.T.			24V (factory ready, optional)
Combustion Air Inlet	4" O.D.		Ignition System: 120V Hot Surface Ignition	
Vent Connection	4" O.D.			

CLEARANCES TO COMBUSTIBLES

Clearances to combustibles	Top (Above Reflector)	Back (Back of angled reflector)	Sides	Below (Reflectors flat)	Below (Reflectors angled)
All Models	4" (10 cm)	4" (10 cm)	18" (46 cm)	36" (92 cm)	30" (76 cm)

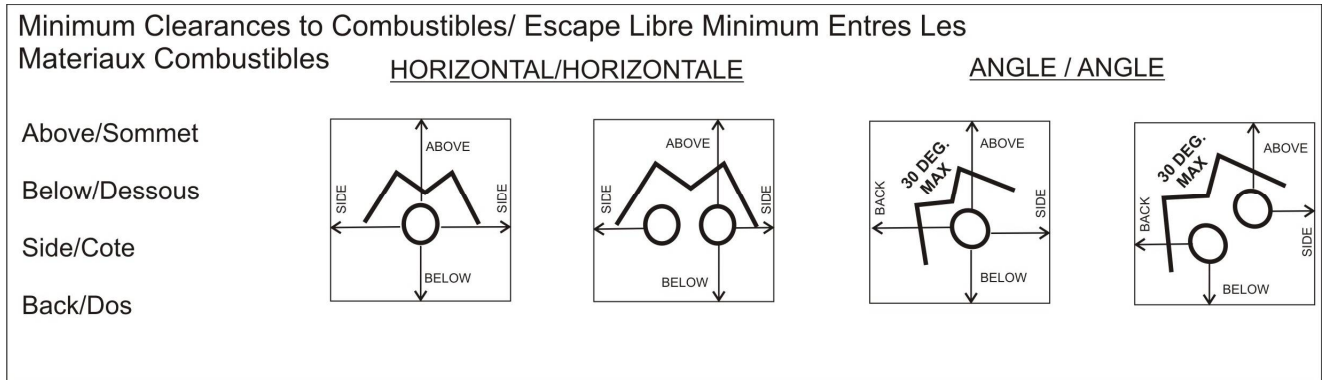

The clearance to combustible materials represents the minimum distance that must be maintained between the heater and a nearby surface.

The stated clearance to combustible materials represents the minimum distance that must be maintained between the outer heater surface and a nearby surface. The stated clearance to combustibles represents a surface temperature of 90 degree Fahrenheit (32 degrees Celsius) above room temperature. Building material with a low heat tolerance (such as plastics, vinyl siding, canvas, tri-ply, filmy materials, fabrics, etc.) may be subject to degradation at lower temperatures. It is the installer's responsibility to assure that adjacent material are not subject to degradation.

In a parking structure, a sign with a warning statement that an overhead heater is present should be installed in a visible location. Minimum required clearances below the heater should be clearly visible so that appropriate distances to combustibles will be maintained to vehicles.

In locations used for the storage of combustible materials, signs must be posted to specify the maximum permissible stacking height to maintain the required clearances from the heater to the combustibles, and that such signs must either be posted adjacent to the heater thermostats or in the absence of such thermostats in a conspicuous location. For your convenience a sign is provided with these instructions. (A sample stacked combustibles warning sign is included in the last page of this manual). See information on "maximum stack height under appliance".

In addition to stored or stationary material, consideration must also be given to moveable objects such as cranes, vehicles, and overhead doors, and structural objects that may have their own specified minimum clearances to heat sources, such as sprinkler heads, electrical and gas lines, and electrical fixtures.

Minimum clearances (cm and inches) from combustibles are measured from the radiant surface.

Clearances are reduced by 1/3, 15 ft (4.6 m) from the burner.

CLEARANCES TO COMBUSTIBLES (CONT.)

For installation at elevations above 2000 ft (610 m), the appliance shall be de-rated 4 percent for each 1000 ft (305 m) of elevation above sea level. Required clearances apply to the appliance rated input, not the de-rated equivalent.



WARNING

Location of flammable or explosive objects, liquids or vapors close to the heater may cause fire or explosion and result in property damage, injury or death. Do not use, store or locate flammable or explosive objects, liquids or vapors in close proximity to the heater. Ensure that adequate distance is maintained from the appliance to any such material that the material cannot reach temperatures that would approach potential flashpoint/ignition/explosion thresholds.



Provide adequate space around the burner and off the gas connection end of the burner to allow for servicing.

Minimum distance from the radiant surface to the floor in non-agricultural installations is 7 ft (2.1 m) in Canada, and 8 ft (2.4 m) U.S.A.

Minimum clearances (inches and cm) from combustibles are measured from radiant surface. The clearances are reduced by 1/3, 15 ft (4.6 m) from the burner.

MAXIMUM STACK HEIGHT BELOW APPLIANCE

In locations used for storage of combustible materials, signs must be posted specifying the maximum stacking height to maintain the required clearances from the heater to combustibles.

For maximum stacking height, deduct listed appliance “below” clearance from the distance from the floor to the appliance emitter tubes.

The signs must be posted either adjacent to the infrared heating system thermostats or in the absence of such thermostats, in a conspicuous place.

See suitable example of warning sign on last page of these instructions.

WARNING



THIS HEATER MUST BE INSTALLED AND SERVICED BY A TRAINED GAS SERVICE TECHNICIAN ONLY. READ AND UNDERSTAND THESE INSTRUCTIONS THOROUGHLY BEFORE ATTEMPTING TO INSTALL, OPERATE OR SERVICE THE GASMACH HEATER. FAILURE TO COMPLY WITH THESE WARNINGS AND INSTRUCTIONS, AND THOSE ON THE HEATER COULD RESULT IN PERSONAL INJURY, DEATH, FIRE, ASPHYXIATION, AND / OR PROPERTY DAMAGE.

DO NOT STORE OR USE GASOLINE OR OTHER FLAMMABLE VAPOURS AND LIQUIDS IN THE VICINITY OF THIS OR ANY OTHER GAS FIRED APPLIANCE

THIS APPLIANCE MAY HAVE SHARP EDGES AND CORNERS, WEAR PROTECTIVE CLOTHING SUCH AS GLOVES AND PROTECTIVE EYE WEAR WHEN SERVICING THIS OR ANY OTHER APPLIANCE.

APPLICATION

This gas fired radiant tube heater may be installed for heating of workshop / garages / commercial / industrial / agricultural / non-residential type spaces. It is beyond the scope of these instructions to consider all conditions that may be encountered. Installation must conform with all local building codes or, in the absence of local codes, to the National Fuel Gas Code, ANSI Z223.1/NFPA54 in the U.S.A. or the Natural Gas and Propane Installation Code, CSA B149.1 in Canada. The latest edition Electrical Code ANSI/NFPA N0 70 in the U.S.A. and PART 1 CSA C22.1 in Canada must also be observed.

This appliance is approved for use in an attached garage only when required building codes have been met for isolation/separation of the garage from the interior of the residence, all required fire and air separations/barriers are in place, and all construction is compliant with all required building and fire codes for such spaces. **In no case can this appliance be installed inside of a residence or domicile including basements, crawl spaces, storage areas, attics, living areas, or other any other attached areas that are not isolated from the building as required by building code.**

Installation of a gas fired tube heater must conform to all heating installation design procedures including clearance to combustibles, connection to the gas and electrical supplies, and ventilation.

This heater is not for installation in a Class 1 or Class 2 explosive environment. If installation of this equipment is in question, consult with local authorities having jurisdiction (Fire Marshall, labour department, insurance underwriter, or others).

Revisions or updates to codes and/or standards may require revision to equipment and installation procedures. In case of discrepancy, the latest revisions of applicable codes, standards, and installation manuals will supersede previous versions.



WARNING

FLAMMABLE/EXPLOSIVE/CORROSIVE VAPORS

Where there is the possibility of exposure to combustible airborne materials or vapour, consult the local fire inspector's office, the fire insurance carrier or other applicable authorities for approval of the proposed installation.

Do not use in an atmosphere containing halogenated hydrocarbons or other corrosive chemicals. Some compounds in the environment can cause an accelerated rate of corrosion to the heat exchanger.

The heater manufacturer cannot anticipate all types and chemical composition of possible contaminants at project sites. Consult with project site safety, health and engineering staff and/or local authorities having jurisdiction such as the Fire Marshall and Department of Labour for possible contaminants and any conflict with the installation of hot surface heating equipment.



WARNING

HEATER EXPANSION

It is a normal condition that during heat-up and cool-down a tube heater will expand and contract. Allowances for heater expansion must be made in the gas connection, venting and combustion air ducting. Consider that the heater will expand in length as much as ½ inch (12.5 mm) or more for every 10 ft (3 m) of system length. Typically, the greater the firing rate, the greater the expansion. Improper installation, alteration, or adjustment can result in property damage, injury or death.



WARNING

GAS CONNECTION

Improper installation, connection, or adjustment can result in property damages, toxic gases, asphyxiation, fire, explosion, injury and/or death. Using an approved flexible gas connector in the USA and Rubber Type 1 hose connector in Canada, the gas supply to the heater must be connected and tested in accordance with all local, state, provincial, and national codes (ANSI Z223.1/NFPA 54 in USA: B149.1 in Canada) and as indicated in the manual. See: **GAS SUPPLY, HEATER EXPANSION, AND FLEXIBLE GAS CONNECTION.**



WARNING VENTING

Inadequate venting of a heater may result in asphyxiation, carbon monoxide poisoning, injury or death. The heater may be directly or indirectly vented from the space. Venting must be in accordance with all local, state, provincial, and national codes (ANSI Z223.1/NFPA 54 in USA; B149.1 in Canada) and as indicated in this manual.



WARNING START-UP SMOKE CONDITION

During start up, the heating of material coatings used in the production process of tubes and reflectors will create smoke and/or odors during the initial period of operation. This condition is normal and temporary. Ensure that there is sufficient ventilation to adequately clear any smoke and/or odors from the space. Notify site and safety personnel to ensure that alarm systems are not unduly activated.

LABOUR REQUIREMENTS

Two persons are required to safely install this equipment. Wear gloves and other required safety protection.

INSTALLATION IN COMMERCIAL AIRCRAFT HANGARS

Low intensity radiant tube heaters are suitable for use in aircraft hangars when installed in accordance with the latest edition of the Standard for *Aircraft Hangars*, ANSI/NFPA No. 409 in the USA, or the *Canadian Natural Gas and Propane Installation Code*, B149.1

A minimum clearance of 10 ft (3 m) above either the highest fuel storage compartment or the highest engine enclosure of the highest aircraft, which may occupy the hangar. The clearance to the bottom of the heater shall be measured from the upper surface of either the fuel storage compartment or the engine enclosure; whichever is higher from the floor.

A minimum clearance of 8 ft (2.4 m) must be maintained from the bottom of the heater to the floor in other sections of the aircraft hangar, such as offices and shops, which communicate with areas for servicing or storage. For proper mounting clearances, refer to the clearances to combustibles in these installation instructions.

Heaters must be located where they are protected from damage to aircraft and other objects, such as cranes and movable scaffolding.

Heaters must be located so as to be accessible for servicing and adjustment.

INSTALLATION IN COMMERCIAL GARAGES AND PARKING STRUCTURES

Low intensity heaters are suitable for use in commercial garages when installed in accordance with the latest edition of the Standard for *Parking Structures*, ANSI/NFPA 88A, or the Standard for *Repair Garages* ANSI/NFPA No. 88B, or the Canadian *Natural Gas and Propane Installation Code*, B149.1

In a parking structure, a sign with a warning statement that an overhead heater is present should be installed in a visible location. Minimum required clearances below the heater should be clearly visible so that appropriate distances to combustibles will be maintained to vehicles.



WARNING

INSTALLATIONS OTHER THAN SPACE HEATING

Use for process or other applications that are not space heating will void the products warranty. Process application requires field inspection and/or certification by local authorities having jurisdiction.



IMPORTANT

Single or multiple heater placements must be such that continuous operation of heater(s) will not cause combustible material or materials in storage to reach a temperature in excess of ambient temperature plus 90 degrees Fahrenheit (32 degrees Celsius).

It is the installer's responsibility to ensure that building materials with a low heat tolerance, which may degrade at lower temperatures, are protected to prevent degradation. Refer to "Clearance to Combustibles" information in these installation instructions.

GENERAL INSTALLATION PROCEDURE

PRE-INSTALLATION SURVEY

It is recommended that a full heating design, including a heat loss calculation be conducted. Heater sizing and placement must consider available mounting height, sources of heat loss, and clearances to combustibles with respect to stored material, moveable objects (cranes, vehicles, lifts, overhead doors, etc) sprinkler systems, and other obstructions on the site. Consideration must also be given to vent / duct placement and the allowable combined lengths of vent and duct.

- Carefully survey the area to be heated and place the burner and combustion chamber in the coldest area if possible.
- The heater shall be hung in such a fashion so as to conform with the clearances to combustibles described on the name plate.
- Clearances to combustibles must be maintained from vehicles parked below.
- Adequate clearances must be maintained for installation in public garages and airplane hangars.
- Verify location with respect to the building construction and equipment, so as to provide sufficient clearances and accessibility for servicing.

PRE-INSTALLATION SURVEY (CONT.)

- The installation must comply with local codes and CAN/CGA B-149.1 in Canada or the National Fuel Gas codes ANSI Z 223.1 (NFPA 54) in the United States.
- Ensure site electrical requirements are met. Consult the latest edition Electrical Code PART 1 CSA C22.1 in Canada and ANSI/NFPA NO 70 in the USA.
- The heating system must have gas piping of the correct diameter, length, and arrangement to supply adequate fuel to allow the appliance to function properly.

APPLIANCE INSTALLATION

Straight, L-Shaped & “U” shaped Heaters

- **Identify and verify all components of tube heater prior to installation.** Appliances ship in components to be assembled on site. Ensure that correct number of primary tubes (tube with sight glass that burner attaches to), and baffle secondary tubes (secondary tube with baffle pre-installed, labeled) are accounted for. Verify that all other components/accessories listed on the factory material packing list are present and accounted for.
- Ensure all hanger supports are in line, and allow for level hanger suspension. Suspend hangers from anchors with suitably rated min. #10 chain, threaded rod, turnbuckle, etc., adhering strictly to the required hanger locations in the following diagrams.
- If hanger locations do not line up with framing as required for support, you may need to securely attach strapping/backing to the structure as required.
- **Attach hanger supporting anchors securely, and directly into building structure only – in no case should any support that anchors only into drywall or other interior wall/ceiling facing be used for installing this appliance.** Refer to section “Suspending The System”
- Ensure that hanger is suspended in a manner that will allow free movement with lateral expansion/contraction of the appliance.
- The first hanger must be no more than 6 inches from the burner.
- For straight unit hangers, suspend from the top ring on the hanger if the reflectors are to be horizontal, and the side ring of the reflectors are to be angled. For U configured units, each side of the hanger must have its own chain and anchor. **IMPROPER HANGER PLACEMENT CAN CAUSE THE RADIANT TUBE TO WARP AND VOID WARRANTY.**
- With hangers in place, the primary tube, and subsequent secondary tube can now be placed in the hangers. Self tapping screws are provided to be installed into the expanded end of the radiant tube. Slide the tubes together making sure that the first tube is inserted all the way into the expanded end of the secondary tube. Install the self-tapping screws at 120 degree intervals to secure the two tubes together. The self-tapping screw holes must be adequately sealed during installation using a suitably rated high temperature RTV silicone sealant.
- Suitably rated high temperature RTV silicone may be applied around tube joints.

Straight, L-Shaped & “U” shaped Heaters (Cont.)

- U-shaped models: connect the 180 degree bend to the radiant tube and securely tighten with self tapping screws provided.
- If using 90 degree elbow on a model ED-40-S unit to achieve an “L” configuration (Part # AC1210), install the elbow between the primary and secondary tube, and secure using the same methods above. Ensure that all lengths of tube are adequately supported, using no less than 2 hangers for each 10’ of total tube length.
- U-shaped models: connect the 180 degree bend to the radiant tube and securely tighten with self tapping screws provided using the methods described above.
- Make sure to secure all tube joints using the 3 screws provided in 120 degree intervals as indicated in the tube assembly diagram below.
- **All ED series units require a baffle. The baffle must be installed at the vent end, located at the extreme opposite end of the heater from the burner.** Baffles are pre-installed in a 10’ section of tube and are clearly labeled.
- Reflectors can now be placed in the hangers. To prevent “walking” of the reflectors, the first and second reflector can be joined together at the overlap with a sheet metal screw
- With the radiant tube and reflectors now installed, the burner can be fitted on the primary tube and secured using the pre-installed set screw. The burner does not require its own hanging support provided the first hanger is no more than 6 inches from the burner joint. **If the first hanger is more than 6 inches from the burner joint, warping of the primary tube may occur and the warranty will be void.**
- Connect the burner to the gas supply using a suitably approved flexible gas connector as outlined in this manual.
- Install exhaust/intake air venting as outlined in this manual.
- Install thermostat control wiring as outlined in this manual.

TUBE ASSEMBLY

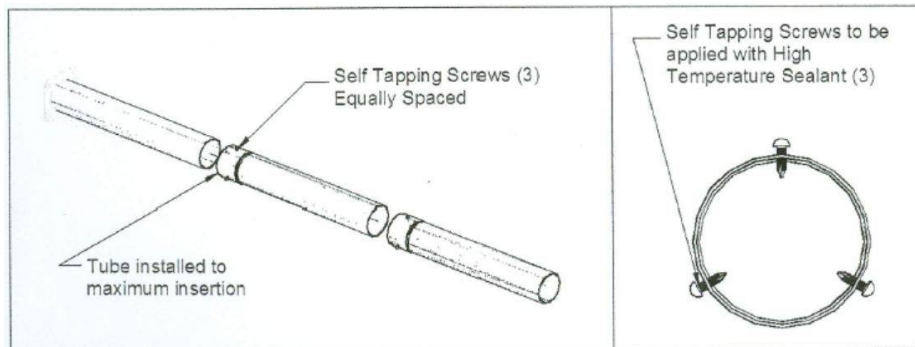

REFLECTOR EXTENSIONS

Reflector extensions (part number P-1930) may be installed on one side or both sides of the reflector as required to reduce lateral heater output on one or both sides of the unit. Reflector extensions are 10 ft long x 9". Drill 3 holes per reflector, and secure extensions to reflector by means of field provided S hooks.

Fig. 1 - Hanger Spacing For Straight Configured Units

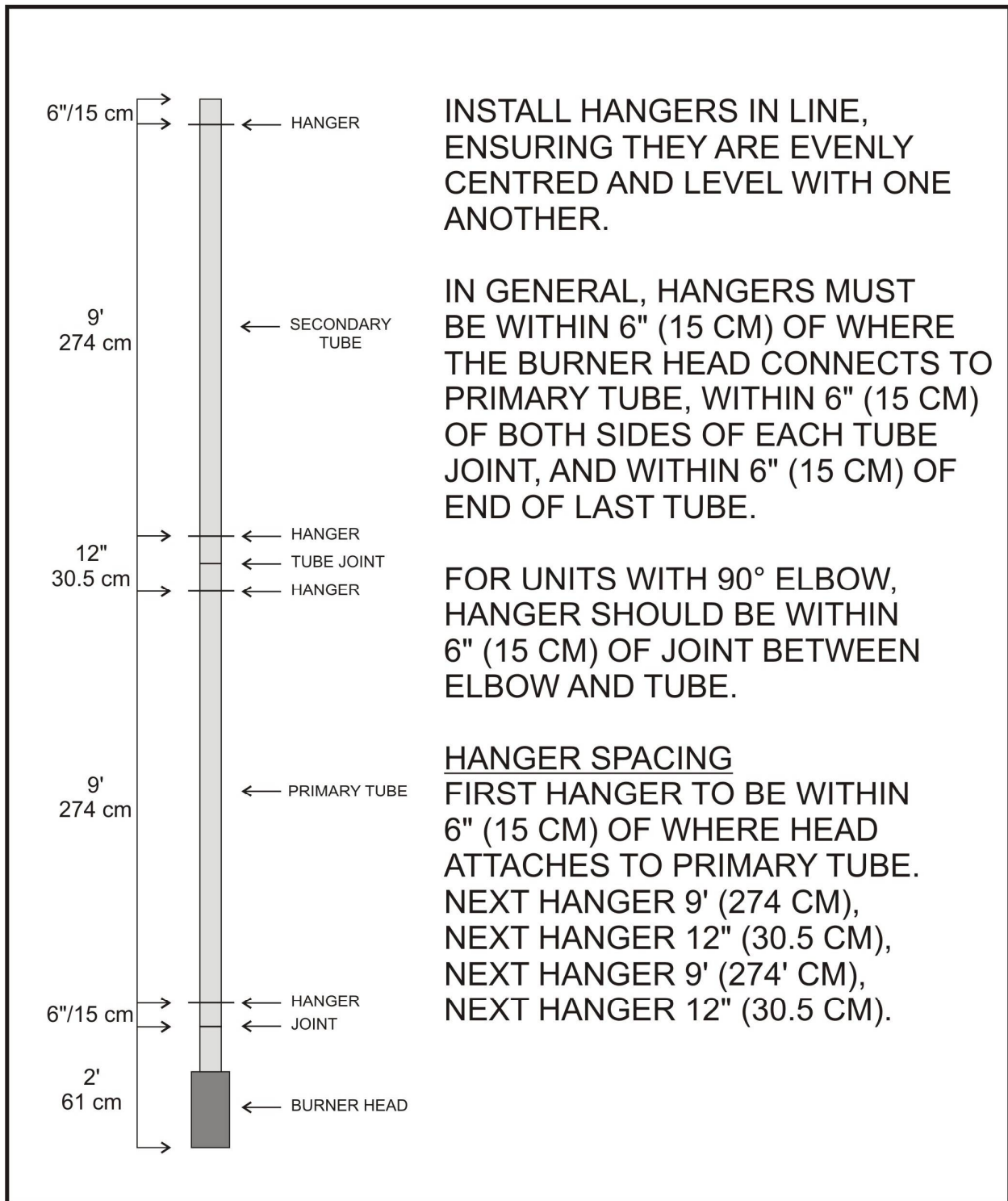

INSTALL HANGERS IN LINE, ENSURING THEY ARE EVENLY CENTRED AND LEVEL WITH ONE ANOTHER.

IN GENERAL, HANGERS MUST BE WITHIN 6" (15 CM) OF WHERE THE BURNER HEAD CONNECTS TO PRIMARY TUBE, WITHIN 6" (15 CM) OF BOTH SIDES OF EACH TUBE JOINT, AND WITHIN 6" (15 CM) OF END OF LAST TUBE.

FOR UNITS WITH 90° ELBOW, HANGER SHOULD BE WITHIN 6" (15 CM) OF JOINT BETWEEN ELBOW AND TUBE.

HANGER SPACING
 FIRST HANGER TO BE WITHIN 6" (15 CM) OF WHERE HEAD ATTACHES TO PRIMARY TUBE. NEXT HANGER 9' (274 CM), NEXT HANGER 12" (30.5 CM), NEXT HANGER 9' (274' CM), NEXT HANGER 12" (30.5 CM).

Fig. 2 - Hanger Spacing For U Configured Units

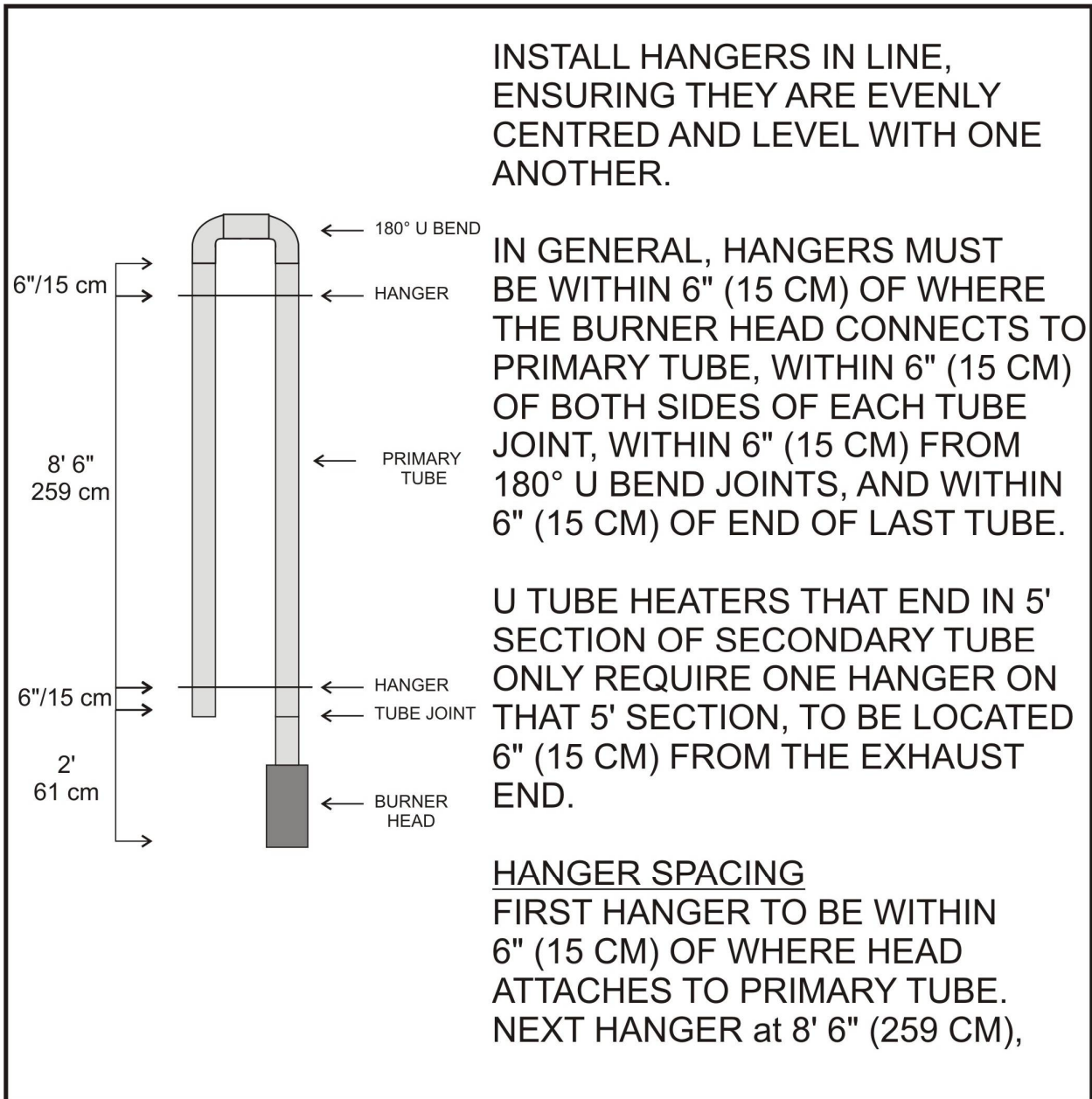

SUSPENDING THE SYSTEM



WARNING

Inadequate or improper suspension of the tube heater can result in collapse of the system, property damage, risk of fire/explosion, personal injury and/or death. It is the installer's responsibility to ensure that the hardware and structural supports from which the heater is suspended are sound and of adequate strength to support the weight and expansion forces of the heater. **In no case should any support that anchors only into drywall or other interior wall/ceiling facing be used for installing this appliance.**

Consider that the heater will expand in length as much as ½ inch (12.7) or more for every 10 ft (3 m) of system length. Typically, the greater the firing rate, the greater the expansion.

Survey the available structural supports, considering the system configuration and heat requirements of the area to establish the optimum heater location. Locating a heater directly under joists or beams, or installing supplemental steel support rail or angle iron can substantially reduce labor and material requirements. Hardware with a minimum 60 lbs (27 kg) workload must be used at each heater suspension point. Connect the structure using typical hardware as illustrated below or by other mechanically sound means.

Typical mounting hardware

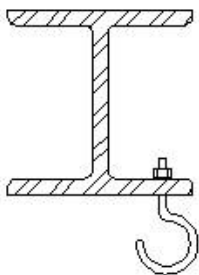

Eye bolt through hole in beam

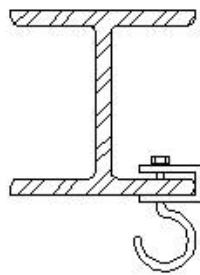

Beam clamp with eye bolt



Eye hook screw



Pipe or clevis hanger

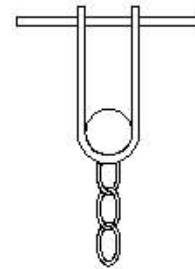

Bar or joist clamp

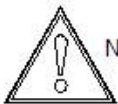

NOTE: It is the installer's responsibility to ensure that the mounting hardware and fastening to the structure are of sufficient strength to support system.



ELECTRICAL/CONTROLS

ELECTRICAL REQUIREMENTS

120VAC / 60 Hz / Single Phase / 1A / 3 Wire Grounded

Starting Current: 3 amps

Running Current: 1 amp

1. Electrical installation must be grounded in accordance with CSA Standard C22.1 part 1 in Canada or The National Electrical code ANSI NFPA 70 (latest edition) in the United States.
2. Polarity of line voltage and neutral wires must be maintained.
3. The total load of all heaters in a circuit must be considered so as to not overload the circuit.
4. Ensure that thermostat wire polarity is maintained.

THERMOSTAT CONTROL

Heaters are designed for compatibility with either 120 Volt (line) thermostat controllers or 24 Volt thermostat controllers. For use with 120 Volt controllers, the heater must be plugged into a “switched” 120 Volt duplex receptacle, where the receptacle is switched by the thermostat controller. Heating zones may be established where one 120 Volt thermostat controls more than one heater, provided the total heater electrical load does not exceed the maximum allowable amperage on the circuit.

For a 24 volt thermostat control, plug the heater into a 120 Volt duplex receptacle. Remove the jumper wire on the control box marked “24 Volt thermostat” and connect the thermostat wire to the terminals. **Do not allow live thermostat wires to contact appliance chassis, or damage to the appliance transformer/controls may occur.** Ensure that if the thermostat has a heat anticipator, the heat anticipator is set at maximum. When using a 24 Volt thermostat, only one heater may be directly controlled by one thermostat unless a system of field supplied relays are utilized.

For 2 stage appliances, connect wires as marked on appliance terminal. Polarity must be maintained. If required, connect thermostat ground to appliance ground post.

GAS SUPPLY PIPING

1. All gas piping and connections shall be made in accordance with all applicable local codes and the latest versions of CAN/CGA B-149 or ANSI standard Z223.1.
2. Connect the burner to gas supply with flexible gas connector.
3. A drip leg must be installed in the gas line at the heater inlet connection tee followed by a pipe drop to the heater. Failure to provide a drip leg could result in condensation and foreign matter passing into the gas valve. Failure to install a drip leg in the gas line can cause property damage, injury or death and will void the heater warranty.

CAUTION: Ensure that flexible gas connectors are installed correctly to allow for heater expansion/contraction during operation. Install flexible connectors as follows:

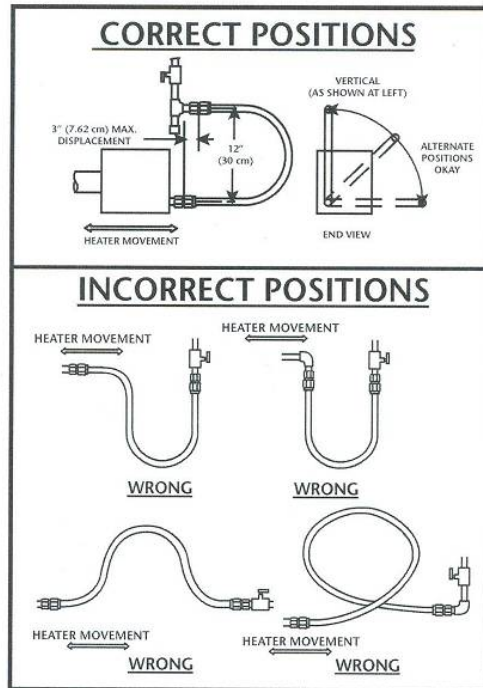

Figure 1. Installation Position Instructions

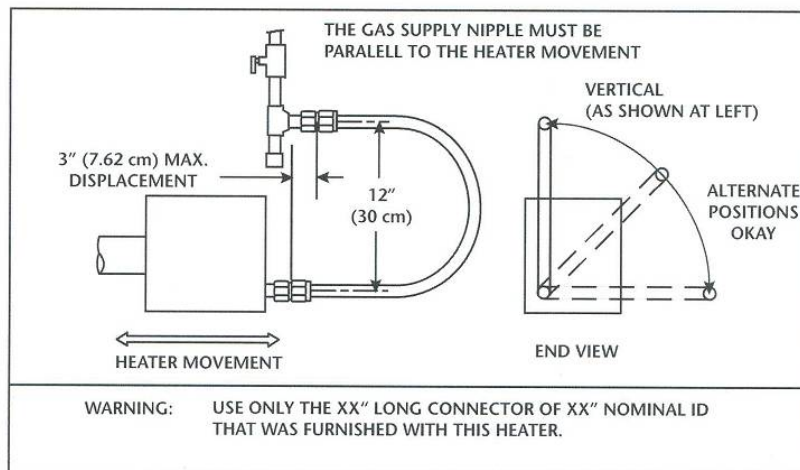

Figure 2. Connector Installation Label



WARNING

Never use a match or other flame to test for gas leaks. Use soap and water solution to check for leaks to all connections and joints and if bubbles appear, leaks have been detected and must be corrected. Never operate an appliance with leaking fuel supply system. The supply system should be checked first with appliance turned off followed by another check while appliance is operating.

GAS SUPPLY, HEATER EXPANSION, AND FLEXIBLE GAS CONNECTION

The required flexible gas connector must be used, and are available from the manufacturer. Flexible gas connectors used from alternate sources must adhere to the following Standards:

The connection of a radiant tube type infrared heater to the gas supply line, in particular taking into account the heater's thermal expansion and contraction, the gas supply must be installed using:

In Canada a type 1 hose connector that is certified as being in compliance with the *Standard for Elastomeric Composite Hose and Hose Couplings for Conducting Propane and Natural Gas*, CSA 8.1; and of a length of 36 ± 6 in (91 ± 15 cm) with an ID of a least $\frac{1}{2}$ in (12.7 mm).

In USA an approved Stainless Steel Flexible Gas Connector certified for use on an infrared radiant tube heater per the *Standard for Gas Appliances* ANSI Z21.24 CSA 6.10. and comply with a 24 in (610 mm) to 36 in (91 cm) long connector with an ID of a least $\frac{1}{2}$ in (12.7 mm).

Heaters installed with maximum thermal expansion of up to 2 in (50 mm) shall be installed with a 24 in (610mm) to 35 in (91 cm) long connector with an ID of a least $\frac{1}{2}$ in (12.7 mm) and;

Heaters with maximum thermal expansion of up 3 in. (76.2 mm) shall be installed with 36 in (91 cm) long connector with an ID of a least $\frac{1}{2}$ in (12.7 mm) and; heaters with maximum thermal expansion of more than 3 in (76.2 mm), but less than 6 in shall be installed with a 36 in (914 mm) long connector with an ID of at least $\frac{3}{4}$ in (19.05 mm).

The distance between the distal mounting positions shall be measured with the appliance "OFF" at ambient temperature and at normal operating temperature. The difference between the two distances shall be used to select an appropriate flexible connector.

Also the flue vent, and combustion air intake (if used) must be installed in such a manner that the normal expansion of the heater will be accommodated



WARNING

HEATER EXPANSION

Consider that the heater will expand in length as much as ½ inch (12.5 mm) or more for every 10 ft (3 m) of system length. In general, the greater the appliance firing rate, the greater the rate of expansion.

This heater will expand in length as it heats up. It is a normal condition that during heat-up and cool-down a tube heater will expand and contract. Allowances for heater expansion must be made in the gas connection, venting and combustion air ducting. Improper installation, alteration, or adjustment can result in property damage, injury or death.

The BTU input and the tube length determine the overall expansion that occurs. A typical infrared tube installation will expand toward both the burner and the vent end.



Compensation for normal gas supply pipe expansion and radiant tube heater expansion must be provided. All piping must conform to local codes. Provide a 1/8 in (3.2 mm) NPT plugged tapping, accessible for test gauge connection, immediately upstream of the gas supply connection to the heater.

Test for leaks. All gas piping and connections must be tested for leaks after the installation is completed.

The heater must be isolated from the gas supply piping system by closing its individual manual shut off valve (field supplied) during any pressure testing of the gas supply piping system.

Apply soap solution to all connections and joints and if bubbles appear, leaks have been detected and must be corrected. Do not use a match or open flame of any kind to test for leaks. Never operate a heater with leaking connections.

The gas supply system should be checked first with the heater turned off followed by another check with the heater turned on.

IMPORTANT: To ensure adequate gas supply pressure at maximum potential load, the supply gas pressure must be checked at all appliances when all heaters, as well as any other gas appliance that is drawing from the same system, are ignited and operating.

VENTING REQUIREMENTS

VENTING TO THE OUTSIDE

In all cases, appliance venting must satisfy all requirements of the most recent versions of the *National Fuel Gas Code*, ANSI Z223.1/NFPA 54, or the *Natural Gas and Propane Installation Code*, CSA B149.1, and any other provisions made by local authorities having relevant jurisdiction.

MATERIALS

This unit is listed as a Category I appliance for both horizontal and vertical venting. All venting must be conventional venting material, with a minimum 26 gauge single-wall metallic gas vent pipe of at least 4" (10 cm) diameter, with a suitably rated thimble used for all combustible wall penetrations. Type "B" vent or an agency certified side wall vent thimble or roof stack system approved for use with category I appliances may also be used for combustible wall/roof penetrations. Unless otherwise specified by the vent manufacturer, minimum clearances to combustibles for un-insulated single wall vent materials is 6" (15 cm).

Agency certified single wall, double wall, and insulated venting systems must meet or exceed the above criteria. Transitioning between single wall, double wall or insulated vent materials as requirements dictate is permitted. In cases where a manufactured venting system's certified installation instructions contravene this manual (e.g., vent lengths, vent clearances, number of elbows, transitions, required terminations, etc.) defer to the specifications outlined in the venting system's manual. **In cases where suitability for a manufactured vent system is in question, contact Easy Radiant Works, the vent manufacturer, or the local gas authority having jurisdiction for clarification.**

VENT LENGTHS

Minimum Vent Lengths: A minimum total length of 36" (91 cm) of venting material is required for this heater. A minimum vent length of 12" (30 cm) is required prior to any vent elbow or tee in the exhaust venting.

Maximum Vent Lengths: The maximum allowable length of vent pipe is 30 ft (9.1 m). This length includes the combination of inlet air vent for combustion and exhaust venting. **THE RADIANT TUBE IS NOT INCLUDED IN THE MEASUREMENT.** For every 90 degree bend in the system, 5 ft (1.5 m) must be deducted from the total allowable vent length. Exceeding these allowable lengths may create condensation or soot conditions and will void appliance certification and warranty.

If using single wall un-insulated vent material longer than 25 feet (7.6 m) it is recommended that the venting after the 25' (7.6 m) mark be of a insulated material, or insulated with a suitable insulation material that is approved and specified by the insulation manufacturer to withstand temperatures up to 450 F (232 C). Insulating single wall venting in situations where excessive condensation occurs is also recommended.

EXHAUST VENT TERMINATION SPECIFICATIONS

Clearances from the exhaust vent termination are determined by local or national codes, but must not be less than 6" (15 cm.) from any combustible materials. All building materials must be adequately protected from potential degradation by flue gases.

For unvented installations, a minimum distance of 48 in. (122 cm) is required horizontally from the end of the heater to a combustible surface. Vent termination must be oriented in a downward direction to direct exhaust flow away from combustible materials above.

Distances from exhaust vent termination to adjacent public walkways, adjacent buildings, windows, and building openings must be consistent with the *National Fuel Gas Code*, ANSI Z223.1/NFPA 54, or the *Natural Gas and Propane Installation Code*, CSA B149.1.

CANADA SPECIFIC EXHAUST VENT TERMINATION REQUIREMENTS:

A vent will not terminate:

- Within 6 ft (1.8 m) of a mechanical air supply inlet to any building. Above a gas utility meter and regulator assembly with 3 ft (0.9 m) horizontally of the vertical centerline of the regulator vent outlet to a maximum vertical distance of 14 ft (4.5m).
- Within 3 ft (90 cm) of any gas pressure regulator vent outlet.
- For units with inputs of up to 100,000 BTUH: Within 12 in. (30 cm) of a window or door that can be opened in any building, any non-mechanical air supply inlet to any building, or of the combustion air inlet of any other appliance.
- For units with inputs over 100,000 BTUH: Within 36 in. (91.5 cm) of a window or door that can be opened in any building, any non-mechanical air supply inlet to any building, or of the combustion air inlet of any other appliance.
- Less than 7' above a paved driveway/sidewalk/path

U.S.A. SPECIFIC EXHAUST VENT TERMINATION REQUIREMENTS:

- The bottom of the vent terminal and the air intake shall be located at least 12 in (30 cm) above grade.

A horizontal vent will not terminate:

- Less than 3 ft (90 cm) above a mechanical air inlet located with 10 ft (3.1 m).
- Less than 4 ft (1.2 m) below, 4 ft (1.2 m) horizontally from, and 1 ft (0.3 m) above any window or door that opens, or gravity air inlet to a building.
- Less than 4 ft (1.2 m) horizontal clearance from gas and electric meters, regulators and relief equipment.

TERMINATION CAPS

When venting through the side wall with a vent material that does not have a specific side wall termination cap requirement, a Easy Radiant Works approved vent spout or exhaust cap must be used (part numbers AC1180 for 4" OD cap, AC1190 for 4" ID cap).

When venting through the roof, a suitable roof stack system that adheres to the above material requirements must be used. When vent and combustion air are taken through the roof, the exhaust vent should always terminate higher than the combustion air intake, to prevent recycling the products of combustion back into the heater.

TERMINATION CAPS (cont.)

Adhere to all current local codes and/or ANSIZ223.1 / CSA.B149.1 latest editions for all venting requirement and practices.

When venting with a manufactured vent system, vent termination caps must be of a design that prevents direct wind infiltration into the venting system. If wind is permitted to infiltrate into the venting system, static pressure may build and trip the appliance blocked flue sensor, resulting in nuisance appliance shutdowns.

GENERAL EXHAUST VENT INSTALLATION REQUIREMENTS

- All vent pipe used with a slip fit connection must be mechanically secured by means of 3 stainless sheet metal steel screws at 120 degree intervals.
- All vent pipe used that does not have a manufactured gasket/sealing mechanism must be sealed with a suitably rated high temperature RTV type silicone at all joints, in addition to sealing any screw penetrations.
- If a seam is present in a single wall duct material, orient the seam to the top side of the duct, and apply high temperature RTV silicone and/or suitable metal tape as required to ensure that the seam is gas tight.
- All venting used must be adequately supported to prevent sagging.
- When the vent pipe passes through a cold or unheated area where the ambient temperature is likely to produce condensation of the flue gases, the vent pipe must be insulated with a suitable insulation material that is approved and specified by the insulation manufacturer to withstand temperatures up to 450 F (232 C).
- Blockages of air intake and exhaust vent caps by snow and/or ice must be prevented.
- A maximum of 3 90 degree elbows may be installed in any vertical exhaust vent system.
- Maintain a downward slope on the venting material of no more than 1/4" per foot (6.3 mm) from the start of the vent system to the vent terminal. Do not apply downward slope to the appliance itself, it must be installed to be horizontally level.

COMMON EXHAUST VENTING OF APPLIANCES

A maximum of two units may be exhausted on a common 6" vent with the use of the factory supplied AC1120 4"x 4"x 6" (10 x 10 x 15 cm) exhaust T, for both side wall and roof venting. A suitably rated and certified high temperature exhaust cap must be used on the end of the 6" exhaust vent.

CAUTION: Units with common exhaust must be jointly controlled.

The addition of the AC1120 exhaust T incorporates a 90' degree bend into the venting of each unit, deducting 5' (1.5 m) from the allowable total of exhaust/intake venting for each commonly vented unit.

UNVENTED INSTALLATION (INTERLOCKED INDIRECT VENTING)

This appliance is certified for installation in structures that are not attached to a residential/domicile type building, without a direct exhaust vent connection to the outdoors, subject to the following criteria.

CANADA: It is required that the heaters(s) be electrically interlocked to dedicated exhaust fan(s) by means of an Air Proving Switch. Exhaust fan(s) must be sized to create 300 cfm (8.5 cu m/min) exhaust for every 100,000 BTUH (30 kW), or a fraction thereof of total input, of installed equipment. Exhaust must be located as high as practicable in the structure above the level of the heater(s). Sufficient supply air must be provided. Consult the latest edition of CSA.B149.1 Section 8 for venting system and air supply requirements.

USA: Natural or mechanical means shall be provided to supply and exhaust at least 4ft³/ min/1000Btuh (0.38m³/min/kW) input of installed heaters. Some local codes may require an electrical interlock to a dedicated exhaust fan. Exhaust must be located as high as practicable in the structure above the level of the heater(s). Consult your local code and ANSI Z223.1 latest edition for all venting requirements and practices.

UNVENTED INSTALLATION IN AGRICULTURAL APPLICATIONS

When installed in a large and adequately ventilated space (agricultural building used only for brooding purposes) the heater may be installed un-vented without interlocking to an exhaust fan, and may be operated by discharging the combustion products directly into the space, subject to the approval of the authority having jurisdiction and provided that the maximum input of the appliance does not exceed 20 BTUH ft³ (0.2 kWm³) of the space in which the heater is located. An environment control system that maintains and monitors a controlled atmosphere need not be subject to these conditions.

COMBUSTION AIR INTAKE VENTING REQUIREMENTS

This appliance can draw combustion air from indoors, or utilize the factory installed air intake duct collar located on the blower assembly to duct combustion air in from outside.

CAUTION: When the appliance is located in a building with a negative air condition, or in a dusty or dirty atmosphere such as a welding shop, wood working shop, poultry barn or foundry, it is mandatory to duct combustion air from outdoors or from an area free of the negative pressure conditions / contaminated air.

Air intake duct must be a minimum of 4" (10 cm) in diameter, gas tight, and constructed of a suitable rigid material that will be able to withstand general environmental conditions.

Any 90 degree bends in the combustion air intake venting reduces the total allowable combined intake/exhaust venting by 5' (1.5 m)

The air intake duct must not be directly connected to the appliance. It is mandatory that a heavy duty metal flexible duct be installed between the appliance air intake duct collar and the intake air ducting to allow for free expansion/contraction of the appliance. (See accessory AC1220 – Air Intake Flex Duct/Cap Kit)

Combustion air intake may be drawn either horizontally or vertically, and must be protected with a suitable screened cap to prevent pest/debris infiltration of the duct. Do not use termination caps that utilize a damper or flapper system. (See accessory AC1220 – Side wall air Intake Flex Duct/Cap Kit. Roof caps are field supplied.)

Air intake terminations shall not be located less than 3 ft (90 cm) above grade, and must be adequately protected from potential blockages due to snow/ice/debris accumulation.

Ensure adequate clearance around the air intake to allow sufficient combustion air supply to the heater. It is recommended that any single wall pipe containing cold air be insulated to prevent or reduce nuisance condensation on the duct surface.

Appliances may not share common air intake ducting except in cases where those appliances are jointly controlled.

In situation where indoor air is especially humid (e.g., carwash applications, food processing, etc.) it is recommended that combustion air be drawn from an alternate source. Ensure that all venting materials used are suitable to withstand high moisture conditions (e.g., stainless steel, ABS, PVC, etc.).



WARNING

Never use a flexible duct as the only means of combustion air intake duct. Flexible ducts are meant to be used as a flexible transition from the burner assembly to a rigid duct only.

Plastic flexible duct and light duty residential “dryer vent” type ducts are not suitable for this purpose.

Venting Insulated Type Vent Material Through Side Wall

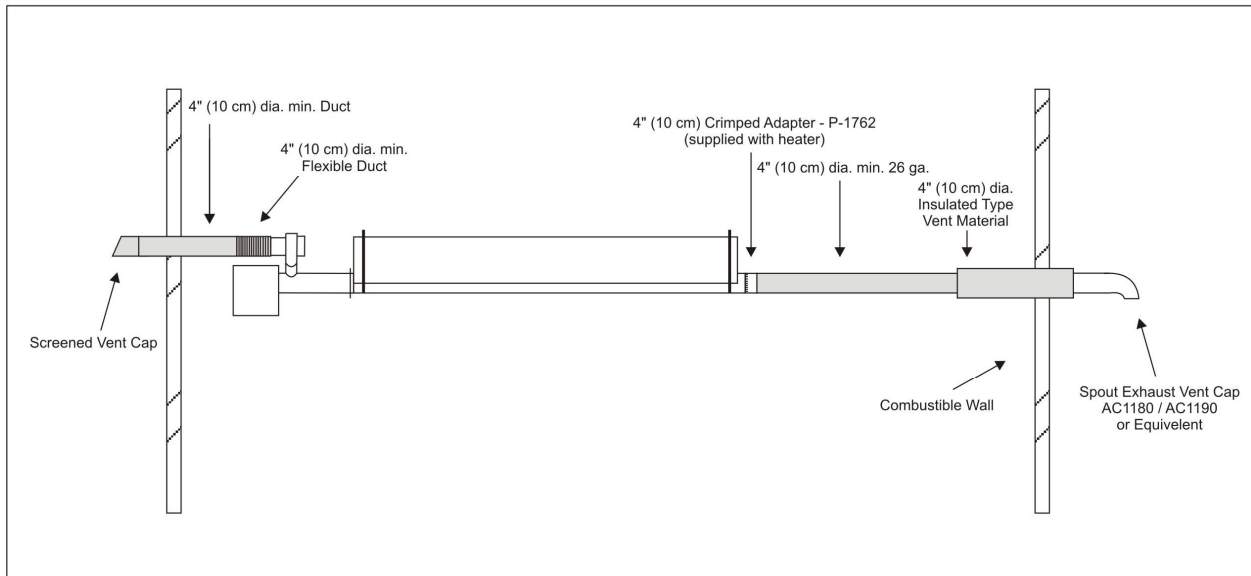

Venting Single Wall Type Vent Material & Thimble Through Side Wall

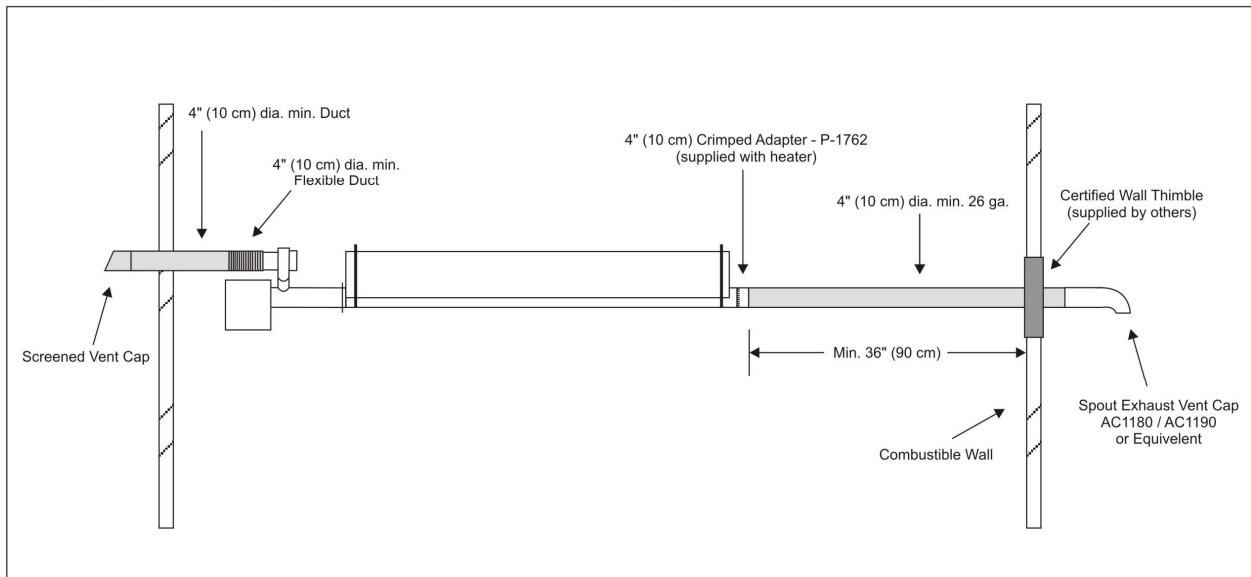

Venting Through Roof

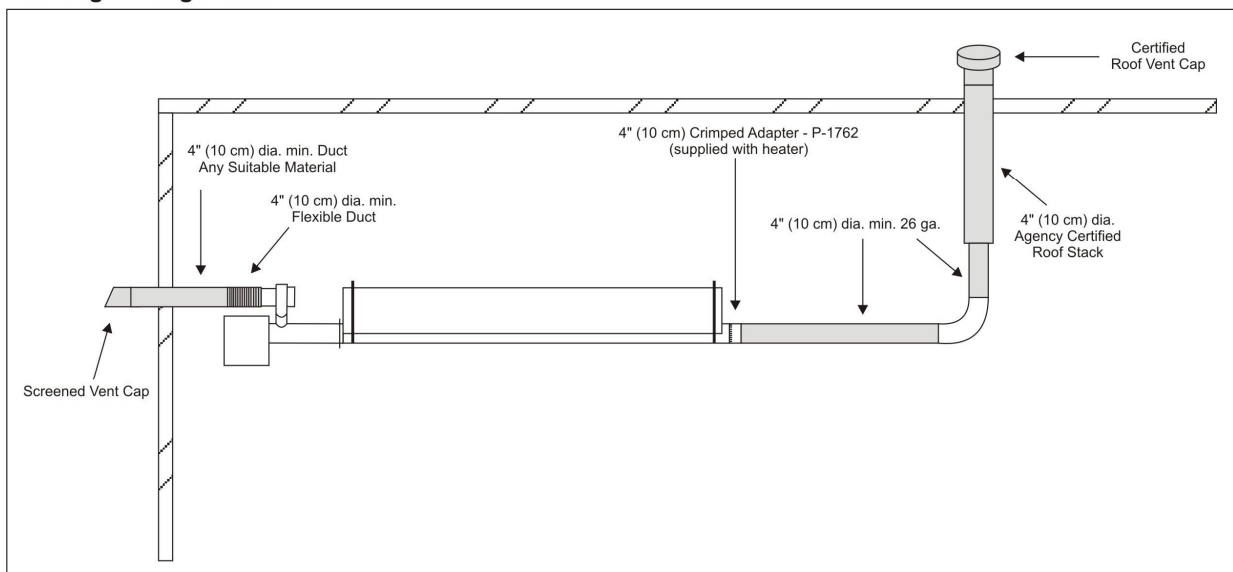

GASMAC ACCESSORIES

4" OD Wall Spout Exhaust Cap
AC 1180

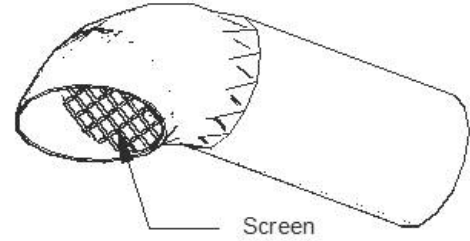
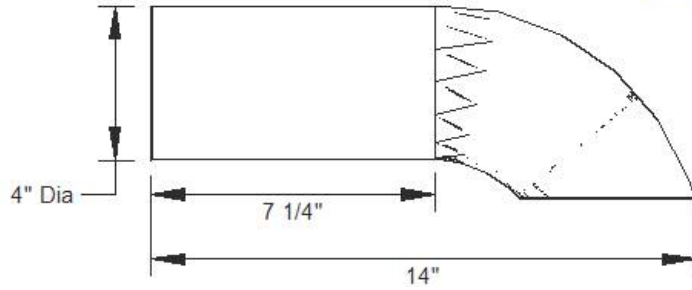

NOTE: FOR EXPANDED 4" ID END, ORDER PART # AC1190

Brooder Exhaust Cap 4"
AC 1170

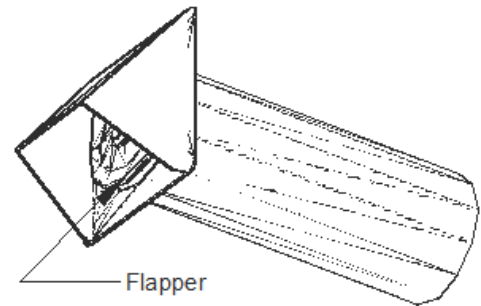
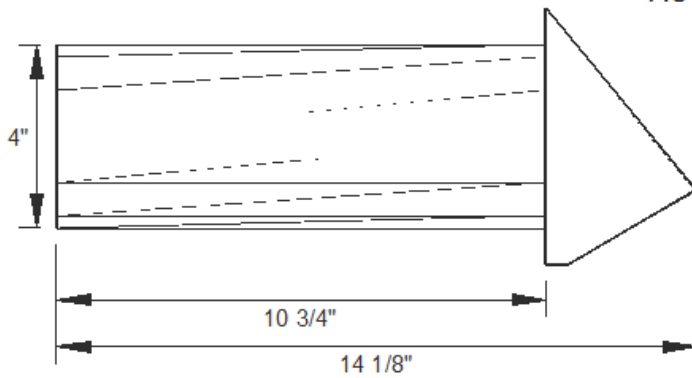

Outside Air Cap 4" Dia
AC 1100

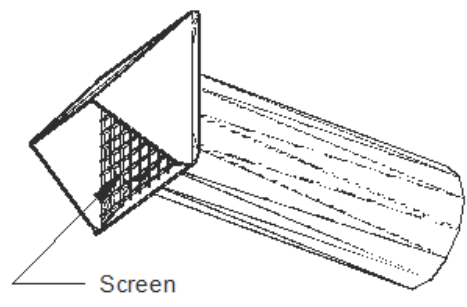
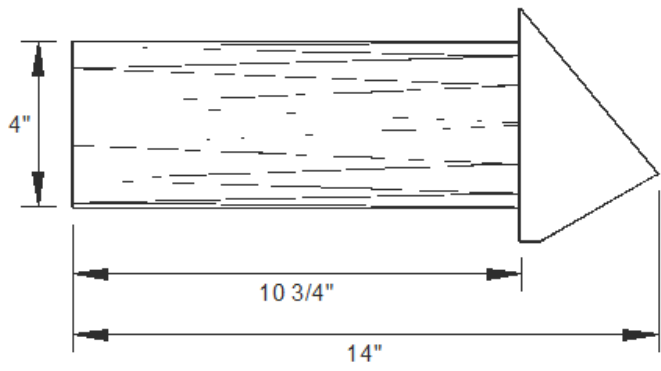

Outside Air Flex Duct 4"
AC 1110

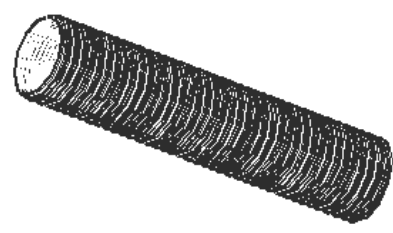
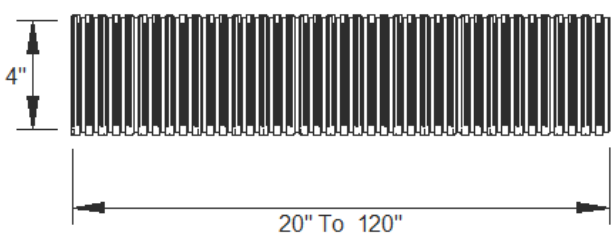

Outside Air Package
AC 1220

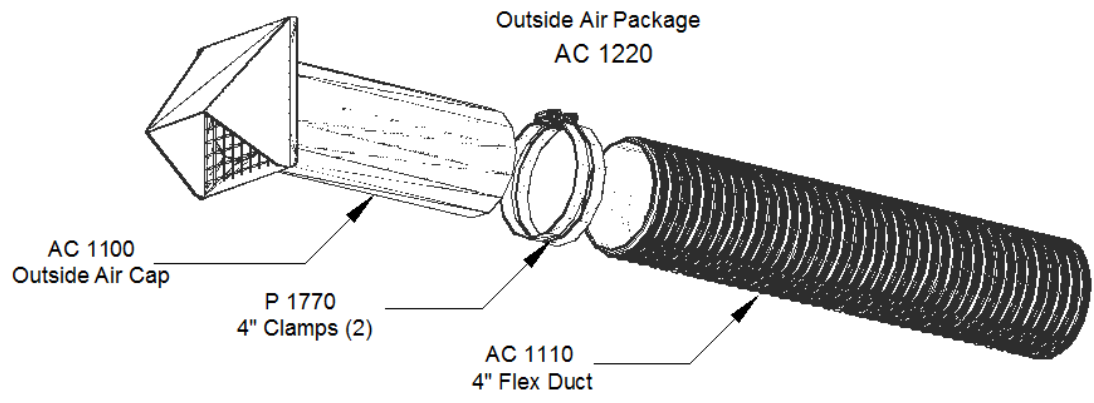

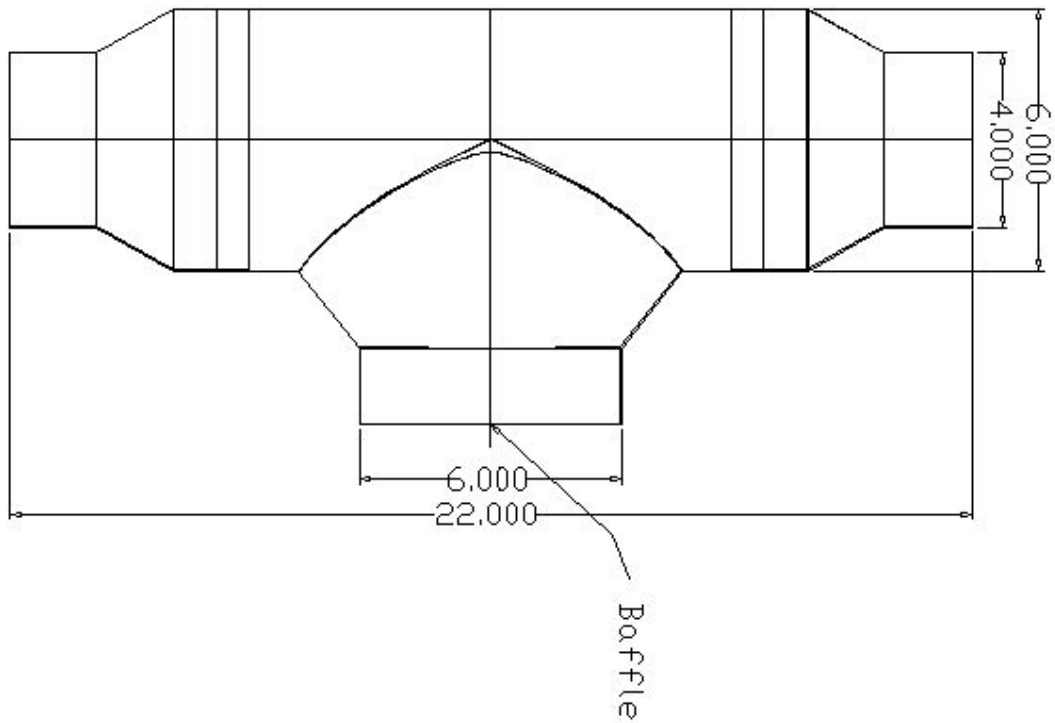

OTHER LISTED ACCESSORIES

AC1010	120V Thermostat	AC1110	4" dia. Combustion Air Flex Duct
AC1060	24V Thermostat	AC1120	4" x 4" x 6" Exhaust Tee
AC1072	½" x 36" Type I Gas Flex	AC1210	3.5" Dia. Emitter 90° Elbow
AC1070	½" x 24" Stainless Steel Gas Flex	AC1220	Combustion Air Intake Kit
AC1080	Outside Air Adapter	AC1085	Attic Air Intake Kit w/Adapter
AC1100	Screened Combustion Air Cap		

TECHNICAL INFORMATION & TROUBLESHOOTING

FIELD CONVERTING APPLIANCES

CAUTION: BEFORE PROCEEDING WITH THE CONVERSION, THE APPLIANCE GAS SUPPLY SHALL BE SHUT OFF PRIOR TO DISCONNECTING THE APPLIANCE ELECTRICAL POWER.

ATTENTION: AVANT DE PROCÉDER À LA CONVERSION, COUPER L'ALIMENTATION EN GAZ PUIS COUPER L'ALIMENTATION ÉLECTRIQUE.

NATURAL GAS AND LIQUID PROPANE CONVERSION:



WARNING

The conversion kit shall be installed by a qualified service agency in accordance with the manufacturer's instructions and all applicable codes and requirements of the authority having jurisdiction. If the information in these instructions are not followed exactly, a fire, an explosion, or production of carbon monoxide may result causing property damage, personal injury or loss of life. The qualified service agency is responsible for the proper installation of this kit. The installation is not proper and complete until the operation of the converted appliance is checked as specified in the manufacturer's instruction supplied with the kit.



AVERTISSEMENT

Cette trousse de conversion doit être installée par un service d'entretien qualifié selon les instructions du fabricant et selon toutes les exigences et tous les codes pertinents de l'autorité compétente. Assurez-vous de bien suivre les instructions dans cette notice pour réduire au minimum le risque d'incendie, d'explosion ou la production de monoxyde de carbone pouvant causer des dommages, matériels, de blessure ou la mort. Le service d'entretien qualifiée est responsable de l'installation de cette trousse. L'installation n'est pas adéquate no complète tant que le bon fonctionnement de l'appareil converti n'a pas été vérifié selon les instructions du fabricant fournies avec la trousse.

FIELD CONVERTING APPLIANCES (CONT.)

NATURAL GAS AND LIQUID PROPANE CONVERSION INSTRUCTIONS:

Note: The maximum certified burner input for any Garagemac unit is 40,000 BTUH.

A field conversion kit is available from natural gas to propane or propane to natural gas. Model no., serial no. and Btu/hr rating are required when ordering conversion kits.

FOR HIGH ALTITUDE APPLICATIONS at elevations above 2000 ft (610 m), the appliance shall be de-rated 4 percent for each 1000 ft (305 m) of elevation above sea level. If the heater is installed at an elevation over 2000 ft (610 m) the installer shall contact the manufacturer, Easy Radiant "Works", for the proper high altitude conversion kit. Exact elevation data is critical for correctly sizing the required conversion kit. Determine the elevation data of the installation site prior to contacting the manufacturer.

The conversion kit will consist of:

- 1) Manufacturer's orifice, stamped w/specific BTUH rating
- 2) A conversion spring kit for associated valve applicable LP or NG label and warning labels indicating their location.
- 3) An installation instruction specific to the associated valve with pictorial illustrations.
- 4) A rating label indicating model no., serial no., btu/hr rating, orifice size, and identification of the gas to which the appliance is to be converted. The conversion rating label must be affixed in a location closest to the existing heater rating plate.
- 5) Label stating "This appliance was converted on ____ (day, month, year) to gas Kit No. ____ by (name and address of organization making this conversion), which accepts the responsibility that this conversion has been properly made". This label must be affixed in a conspicuous location on the heater.
- 6) Label stating "This control has been converted for use with (applicable LP or NG) gas".
- 7) HIGH ALTITUDE APPLICATIONS: Label stating "This appliance was converted on (day, month, year) for operation at ____ ft (____ m) altitude with Kit No. ____ by ____ (name, address of the organization making this conversion), which accepts responsibility that this conversion has been properly made". This label must be affixed in a conspicuous location on the heater.
- 8) Installation / Operating manual for appliance.

Caution: The gas supply shall be shut off prior to disconnecting the electrical power before proceeding with the conversion.

To avoid dangerous accumulation of fuel gas, turn off gas supply at appliance service valve before starting installation.

NATURAL GAS AND LIQUID PROPANE CONVERSION INSTRUCTIONS (CONT.)

- Read the instructions supplied with the conversion kit for details unique to the associated valve carefully. Failure to follow instructions provided with the conversion kit can damage product or cause a hazardous condition, property damage, personal injury or loss of life.
- Remove regulator cap screw and pressure regulator adjusting screw
- Replace the existing spring with the one provided by the manufacturer.
- Re-install regulator cap screw and pressure regulator adjusting screw.
- Replace gas orifice with the one provided by the manufacturer.
- Check the regulator setting using a manometer:
- Remove outlet pressure tap plug from gas control and connect pressure gauge.
- Turn gas control knob to ON position
- To obtain an accurate outlet pressure reading, main burner must be cycled on and off several times to stabilize the pressure regulator.
- Operate heater and read pressure gauge. Adjust pressure regulator if necessary. Refer to the valve conversion kit literature for details unique to the associated valve.
- Remove pressure gauge and replace outlet pressure tap plug and pressure regulator cap screw. Refer to chart below for manifold pressure and maximum and minimum gas pressures of the converted heater.

Gas Supply	Natural Gas	Propane
Manifold Pressure	3.5" W.C.	10.0" W.C.
Min. Inlet Pressure	7.0" W.C.	11.5" W.C.
Max. Inlet Pressure	14.0" W.C.	14.0" W.C.
Max. Outlet Pressure	3.5" W.C.	10.0" W.C.

- Mount the conversion label on the gas control.
- Mount the conversion label on the heater
- Perform gas leak test after completion of installation:
- Never use a match or other flame to test for gas leaks.
- Paint pipe connections upstream of gas control with rich soap and water solution to check for leaks to all connections and joints and if bubbles appear, leaks have been detected and must be corrected.
- Never operate the heater with leaking connections.
- Stand clear of main burner while lighting to prevent injury caused from hidden leaks that could cause flashback in the appliance.
- With burner operating, paint pipe joints (including adapters) and control inlet and outlet with rich soap and water solution.
- Replace part if gas leak cannot be stopped.
- Refer to the Operating Sequence to place system in operation and observe through at least one complete cycle to assure all controls are operating properly.

TROUBLESHOOTING



WARNING

Improper adjustment, alteration, service or maintenance can cause property damage, injury or death. **This heater must be installed and serviced only by a trained gas service technician.**

If at the onset of ignition, no ignition occurs, the following should be checked.

- Check the line voltage (120 V). Ensure that polarity is correct and ground is solid.
- Verify that 120V power supply voltage is adequate and consistent
- Verify that the thermostat is functional, and that thermostat wire is intact.
- Ensure that the appliance blower fan is operational.
- Check for a blocked combustion air inlet or blockage in exhaust venting.
- Inspect for a faulty air switch connection, or damaged air switch air inlet tubing.
- Verify that the blocked flu air switch is operational.
- Verify that the combustion air switch is operational.
- Verify that the 24 Volt transformer is operational.

Having established power at the control, and still no ignition occurs then the control itself is suspect and should be changed.

If the igniter operates and there is still no ignition, then the gas valve is suspect. Be sure that the main gas supply is on, that the gas cock in the drop line is on, and that the shut off cock on the gas valve is open. If all gas cocks are open, then power to the gas valve should be checked. If there is power to the valve and it does not open then the valve should be replaced.

Continued lockout of the control may indicate that the flame sensor is not providing the signal back to the control (flame sensing circuit). If the sensor is in the proper position and the lockout condition continues, then the grounding connections of the burner, control, and transformer should be checked. Proper polarity must be maintained in the building wiring. Reversed polarity or insufficient supply voltage can cause intermittent ignition failure. If this does not solve the problem, then the control is suspect.

Ignition control modules are solid state; computerized devices that require consistent supply voltage while in operation.

See control specific troubleshooting on following pages.

RECOMMENDED MAINTENANCE



WARNING

Improper adjustment, alteration, service or maintenance can cause property damage, injury or death. **This heater must be installed and serviced only by a trained gas service technician.**

- Carry out these steps at a minimum prior to every heating season. It is recommended that they be conducted routinely throughout the heating season as well.
- Inspect the entire heater system; venting and gas supply connections. Replace worn parts and contact a qualified gas technician to repair deficiencies.
- Check the combustion air inlet and the blower, cleaning off any lint or foreign matter that has accumulated. It is important that the flow of combustion and ventilation air must not be obstructed.
- Check the exhaust termination for obstruction. Clear as required.
- Visually inspect the reflector and tube assembly for dust/debris/damage. Clean and/or service as required.
- Run the appliance through a full cycle, verifying that all steps outlined in the Operating Sequence are progressing as outlined. If any aberrant behavior or appliance failures occur, contact a qualified gas technician for service.

The tube heater burner is completely factory assembled and tested. Any alteration voids the certification and manufacturer's warranty. For additional information, contact your local distributor, or the manufacturer.

WARRANTY

ALL Gasmac heaters are covered by a 4 year guarantee. All heaters manufactured by Gasmac are warranted to the original user against defects in materials and workmanship under normal use for a period of 4 years from date of purchase. Gasmac tubes are covered by a 20-year warranty against burn out. Any part that is determined to be defective in material or workmanship during the warranty period, and returned to the manufacturer, shipping costs prepaid, will be, as the exclusive remedy, repaired or replaced at the discretion of the manufacturer. For warranty claim procedures see "Prompt Disposition of Warranty Claims" below.

To the extent allowable under applicable law, the manufacturer's liability for consequential or incidental damages is expressly disclaimed. The manufacturer's liability in all events is limited to and shall not exceed the purchase price paid. Many jurisdictions have codes and regulations governing sales, construction, installation, and/or use of products for certain purposes, which may vary among jurisdictions. While the manufacturer attempts to assure that its products comply with these many codes, it cannot guarantee compliance, or cannot be responsible for how the product is installed or used. Before purchase or use of a product, review the product applications, and all applicable national and local codes and regulations, and ensure that the product and installation will comply with them.

PROMPT DISPOSITION OF WARRANTY CLAIMS

The manufacturer will make a good faith effort for prompt correction or other adjustment with respect to any product that proves to be defective in material or workmanship within the warranty period. For any product believed to be defective under this warranty, first write or call the dealer / retailer from whom the product was purchased. The dealer / retailer will give further instructions. If unable to resolve satisfactorily, write or call the manufacturer at the phone number above giving dealer's name, address, date and number of dealer's invoice, and describe the nature of the defect. Title and risk of loss pass to buyer on delivery to common carrier. If product is damaged in transit to you, file a claim with the carrier.

START-UP/TECHNICAL SUPPORT INFORMATION

This equipment has been factory fired and tested prior to shipment. To ensure that site conditions are compatible with the heater's performance, the following start up needs to be completed by the qualified gas installer.

A technician calling for technical support must provide the information from the following completed reports. Completed reports can be faxed to Technical Support at fax no. 905-899-2262 or call phone no. 905-899-3473, or 1-800-403-3279.



During startup, material coatings used in the production of tubes and reflectors will "burn off" and create smoke and/or odors during the first hour of operation. This is temporary and normal. Please ensure that there is sufficient ventilation to adequately clear the smoke and/or odors from the space. Notify site and safety personnel to ensure that alarm systems are not unduly activated.

CONTRACTOR NAME:

ADDRESS:

CITY

PHONE

JOB SITE

HEATER MODEL NUMBER

HEATER SERIAL NUMBER

DATE

QUALIFIED INSTALLER TO COMPLETE THIS START-UP REPORT
PLEASE RETAIN THIS REPORT FOR TECHNICAL SUPPORT

TYPE OF GAS:	NG	<input type="checkbox"/>	LP	<input type="checkbox"/>
DOES BUILDING HAVE A NEGATIVE CONDITION :	YES	<input type="checkbox"/>	NO	<input type="checkbox"/>
IF THIS IS A HIGH ALTITUDE AREA WHAT IS THE ALTITUDE ABOVE SEA LEVEL				Ft.
DOES APPLICATION REQUIRE FRESH AIR TO BURNER	YES	<input type="checkbox"/>	NO	<input type="checkbox"/>
IS HEATER EXPOSED TO CHEMICAL OR CORROSIVE ATMOSPHERE :	YES	<input type="checkbox"/>	NO	<input type="checkbox"/>
ARE ACTUAL MINIMUM CLEARANCES AS INDICATED IN THE INSTALLATION INSTRUCTIONS	YES	<input type="checkbox"/>	NO	<input type="checkbox"/>
CAN HEATER BE AFFECTED BY OVERHEAD CRANES / VIBRATION	YES	<input type="checkbox"/>	NO	<input type="checkbox"/>
ARE GAS SUPPLY LINES ADEQUATELY SIZED FOR SYSTEM	YES	<input type="checkbox"/>	NO	<input type="checkbox"/>
GAS LINES AND BRANCHES HAVE BEEN PURGED OF AIR :	YES	<input type="checkbox"/>	NO	<input type="checkbox"/>
THIS HEATER FIRED WITHOUT ANY MALFUNCTION :	YES	<input type="checkbox"/>	NO	<input type="checkbox"/>
INLET GAS SUPPLY PRESSURE WITH HEATER OPERATING :		<input type="text"/>		WC"
GAS VALVE OUTLET (Manifold) PRESSURE WITH HEATER OPERATING :		<input type="text"/>		WC"
WHAT IS THE LINE VOLTAGE READING AT THE HEATER		<input type="text"/>		VOLTS
WHAT IS THE VOLTAGE READING AT THE IGNITION MODULE		<input type="text"/>		VOLTS
IS HEATER CONTROLLED BY A THERMOSTAT	YES	<input type="checkbox"/>	NO	<input type="checkbox"/>
IS THE THERMOSTAT STRATEGICALLY LOCATED	YES	<input type="checkbox"/>	NO	<input type="checkbox"/>
WHAT IS TOTAL LENGTH OF INSTALLED THERMOSTAT WIRE		<input type="text"/>		FEET
WHAT IS THE GAUGE OF THE THERMOSTAT WIRE		<input type="text"/>		GAUGE
WHAT IS THE HEATER TUBE LENGTH		<input type="text"/>		FEET
WHAT IS THE TOTAL LENGTH OF THE VENT (add 5ft for each bend)		<input type="text"/>		FEET
WHAT LENGTH IS COMBUSTION AIR INTAKE (add 5ft for each bend)		<input type="text"/>		FEET
IS THERE A BAFFLE INSTALLED IN THE RADIANT TUBE	YES	<input type="checkbox"/>	NO	<input type="checkbox"/>
IF REQUIRED....WHAT IS THE LENGTH OF THE BAFFLE(S)		<input type="text"/>		FEET
IF INSTALLED....IS THE BAFFLE AT FLUE END OF SYSTEM	YES	<input type="checkbox"/>	NO	<input type="checkbox"/>

THIS HEATER MUST BE ELECTRICALLY GROUNDED

TECHNICAL SUPPORT: 1-800-403-3279
FAX: 905-899-2262
WEB: www.easyradiantworks.com

Rev	Description	By	Date	Approved
17620-GDJH				

Note: Neutral wire from blower is connected to Neutral of 120V supply wire.

Terminal	Description
12	Ignitor Rtn
11	120V Rtn
10	Ignitor Hot (120V)
9	Flame Sense
8	Ground
7	Thermostat Hot (24V)
6	120V Hot
5	Blower Hot (120V)
4	Main Valve Rtn
3	Pressure Switch Out
2	Pressure Switch In
1	Main Valve Hot (24V)

Control Timings	
Ignition Trials	3
Ignition Trial	7 sec
Ignition Activation	4 sec
Pre and Inner Trial	0 sec
HSI Warm Up 1st Trial	17 sec
HSI Warm Up 2nd /3rd Trial	27 sec
Lockout Reset	60 min

Electrical Specifications
 Control 24Vac +10/-15%, 60Hz, 0.30A
 HSI 120Vac, 10A max.
 Valve 24Vac, 2A max.
 Blower 120Vac, 10A max.
 Flame Current 1uA min.

Ambient Temp.
 -40 to +175F

Approvals
 CSA #L0641001

LED CODES

Steady ON	Normal Operation
1 Flash	PSW Closed
2 Flash	PSW Open
3 Flash	Ignition Trial Lockout
4 Flash	Flame out of Sequence or Internal Fault

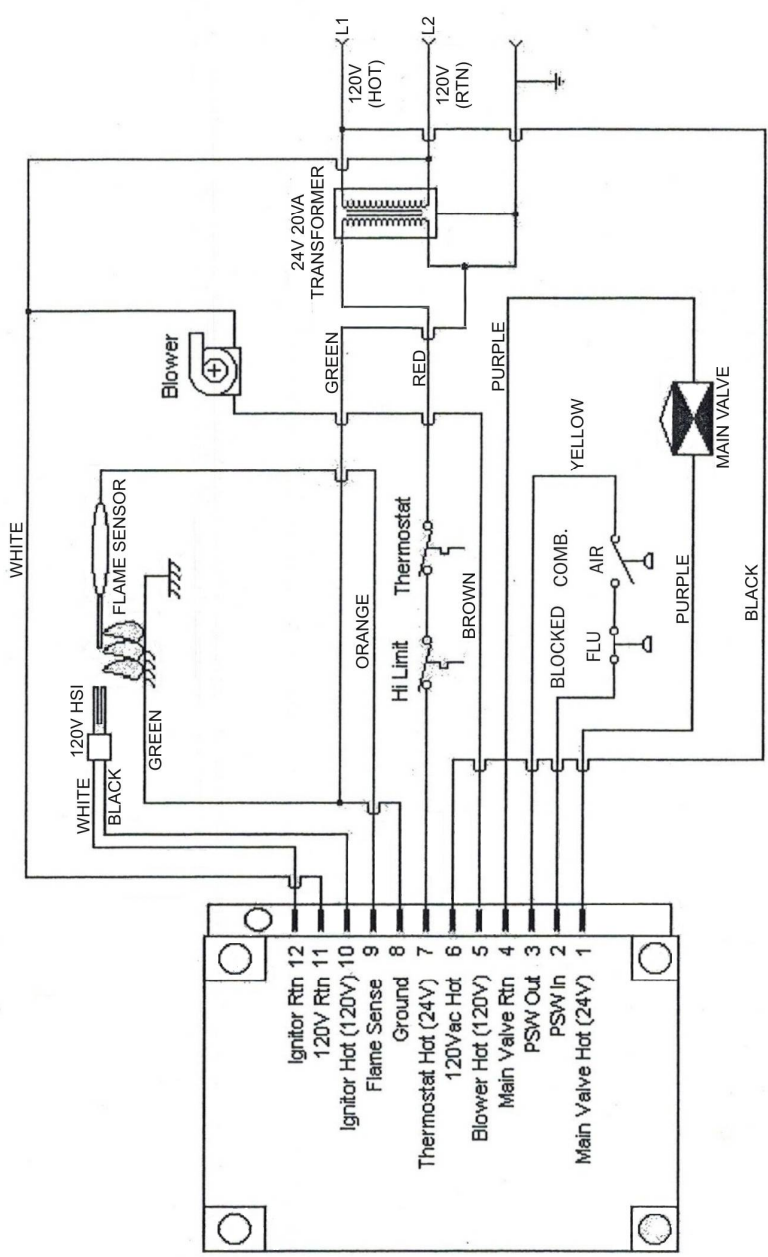

Title: **DH21260K Wiring Diagram**

Drawing: **WD_DH21260K**

ALL RIGHTS RESERVED

COPYRIGHT 2003

SYNETEK DH21260K

LED STATUS	INDICATES	CHECK/REPAIR
OFF	No power to system control.	<ol style="list-style-type: none"> 1. Line voltage input connectors on module. 2. Low voltage 24V and COM connection on module. 3. System wiring harness in good condition and securely connected at both ends. 4. Electrical supply is live and functioning properly.
STEADY ON	Normal Operation. LED is solidly lit when unit is powered, unless some normal abnormal event has occurred.	Not applicable.
1 Flash	Combustion intake airflow proving switch stuck closed at call for heat.	<ol style="list-style-type: none"> 1. Combustion intake airflow proving switch stuck closed. 2. Combustion intake airflow proving switch miswired or jumpered. 3. Combustion intake airflow proving switch operation, tubing, and wiring.
2 Flashes	Airflow proving switch circuit remained open for 30 seconds after blower energized.	<ol style="list-style-type: none"> 1. Airflow proving switch stuck open. 2. Combustion airflow proving switch miswired or jumpered. 3. Blocked flue airflow proving switch stuck open during ignition sequence due to malfunction, blockage, or miswiring. 4. Obstructions or restrictions in appliance air intake system that prevent proper combustion air flow. 5. Airflow proving switch operation, tubing, and wiring.
3 Flashes	Ignition trial lockout. Appliance has failed ignition trial 3 consecutive times. System will reset after 20 minute delay, then initiate a new ignition sequence if the call for heat is still present.	<ol style="list-style-type: none"> 1. Gas supply off or at too low pressure to operate appliance. 2. Damaged or broken HSI element. 3. Line voltage HOT connector not connected to module, or electrical supply failure. 4. Appliance not properly earth grounded. 5. Flame sense rod contaminated or in incorrect position. 6. HSI element located in incorrect position. 7. Hot surface element or flame sense rod wiring in good condition and properly connected. 8. 3 consecutive ignition failures for any cause.
4 Flashes	Flame sensed out of sequence or internal fault. Module self diagnostics have detected a critical fault in module programming/operation.	Replace ignition module.
IF	AND	CHECK / REPAIR
Combustion air blower does not energize.	1 Flash code does not come on 30 seconds after call for heat starts.	<ol style="list-style-type: none"> 1. Combustion air blower wiring, combustion intake airflow proving switch wiring. 2. Combustion air blower.
Combustion air blower does not energize.	1 Flash code does come on 30 seconds after call for heat starts.	<ol style="list-style-type: none"> 1. Airflow proving switch stuck closed. 2. Airflow proving switch miswired or jumpered.
Combustion air blower energized.	2 Flash code does not come on after 30 seconds.	Wait for prepurge time to expire.
2 Flash code comes on 30 seconds after combustion air blower is energized.	Combustions air blower turns off.	<ol style="list-style-type: none"> 1. Airflow proving switch stuck in open position. 2. Airflow proving switch tubing and wiring. 3. Obstruction or restrictions in appliance air intake or exhaust flue system that prevent proper combustion air flow.
30 second prepurge time has expired.	HSI Element does not glow red within 10 to 15 seconds.	<ol style="list-style-type: none"> 1. Broken or damaged HSI element. 2. Broken or damaged HSI element leadwires. 3. Failure to power HSI element. 4. Check voltage on HSI lead to verify module is sending correct output.
HSI elements is glowing red	No other visible control system action.	1. Flame sensor moisture detected. Wait for HSI element to warm/dry flame sensor. Ignition sequence will commence when no moisture is detected on flame sensor.

Rev	Description	By	Date	Approved

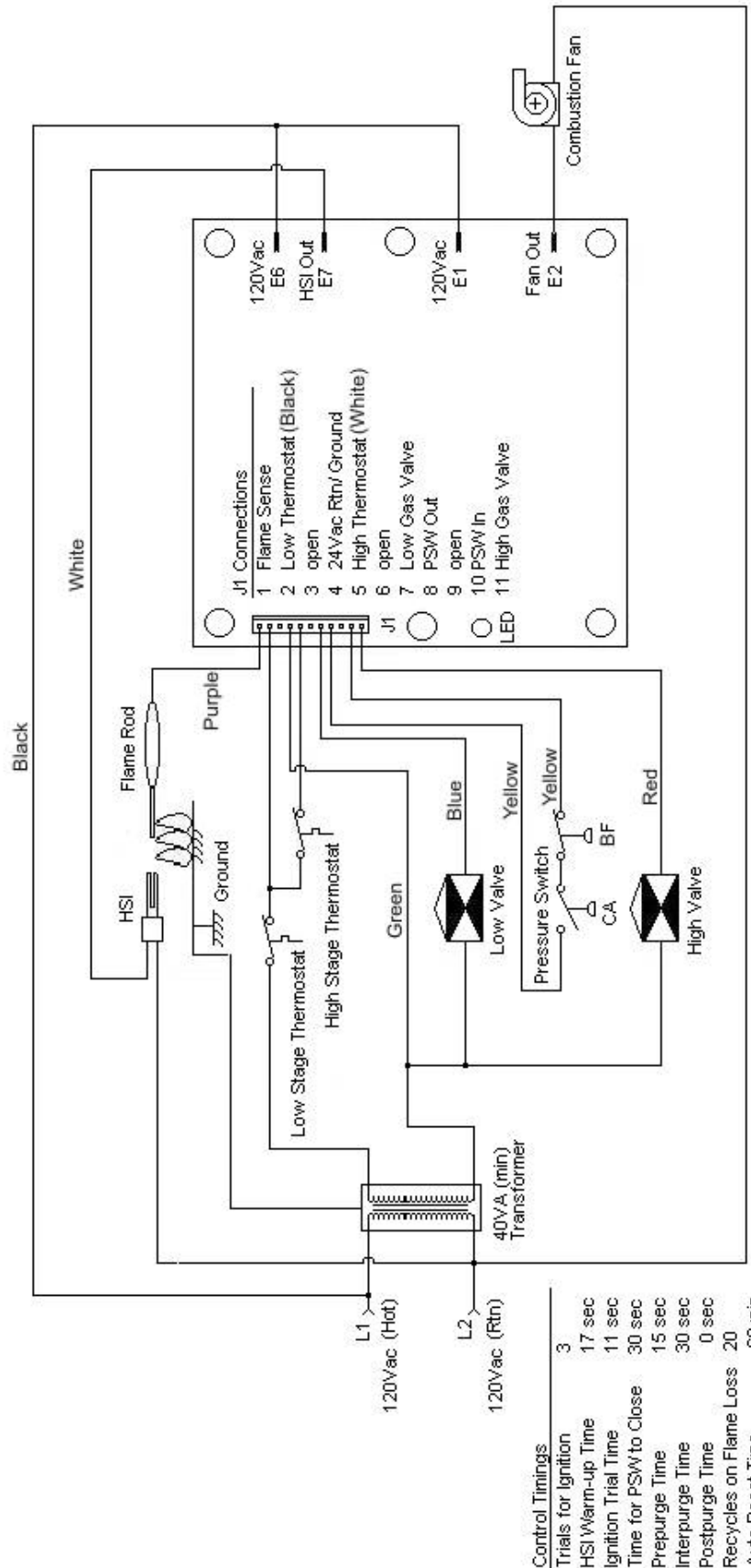

Control Timings

Trials for Ignition	3
HSI Warm-up Time	17 sec
Ignition Trial Time	11 sec
Time for PSW to Close	30 sec
Prepurge Time	15 sec
Interpurge Time	30 sec
Postpurge Time	0 sec
Recycles on Flame Loss	20
Auto Reset Time	60 min

Electrical Specifications

Control	24Vac +10/-15% 60Hz, 0.3A
HSI	120Vac, 5.0A max.
Low Valve	24Vac, 5.0A max.
High Valve	24Vac, 5.0A max.
Low Tstst	24Vac, 30mA
High Tstst	24Vac, 30mA
F.Current	1uA
Comb. Fan	120Vac, 15A max

LED Codes

1 Flash	Flame Detected Out of Sequence
2 Flash	Ignition Trial Lockout
3 Flash	Flame Loss Lockout
4 Flash	PSW In Wrong Position
OFF	No Power or Internal Fault
ON	Normal Operation

Approvals

Approvals	CSA L0641001
-----------	--------------

Ambient Temperature
-40F to +175F

.250" Male Quick Connects

E6	120Vac In (HSI)
E7	120Vac HSI Out
E1	120Vac In (Fan)
E2	120Vac Fan (Out)

Title:	
DH21390CrA Wiring Diagram	
Drawing: WD_DH21390C_A	

Drawn By	Date
Checked	Date
Engineer	Date
App. By	Date
App. By	Date

SV9510M SMART VALVE

COMBUSTION AIR BLOWER

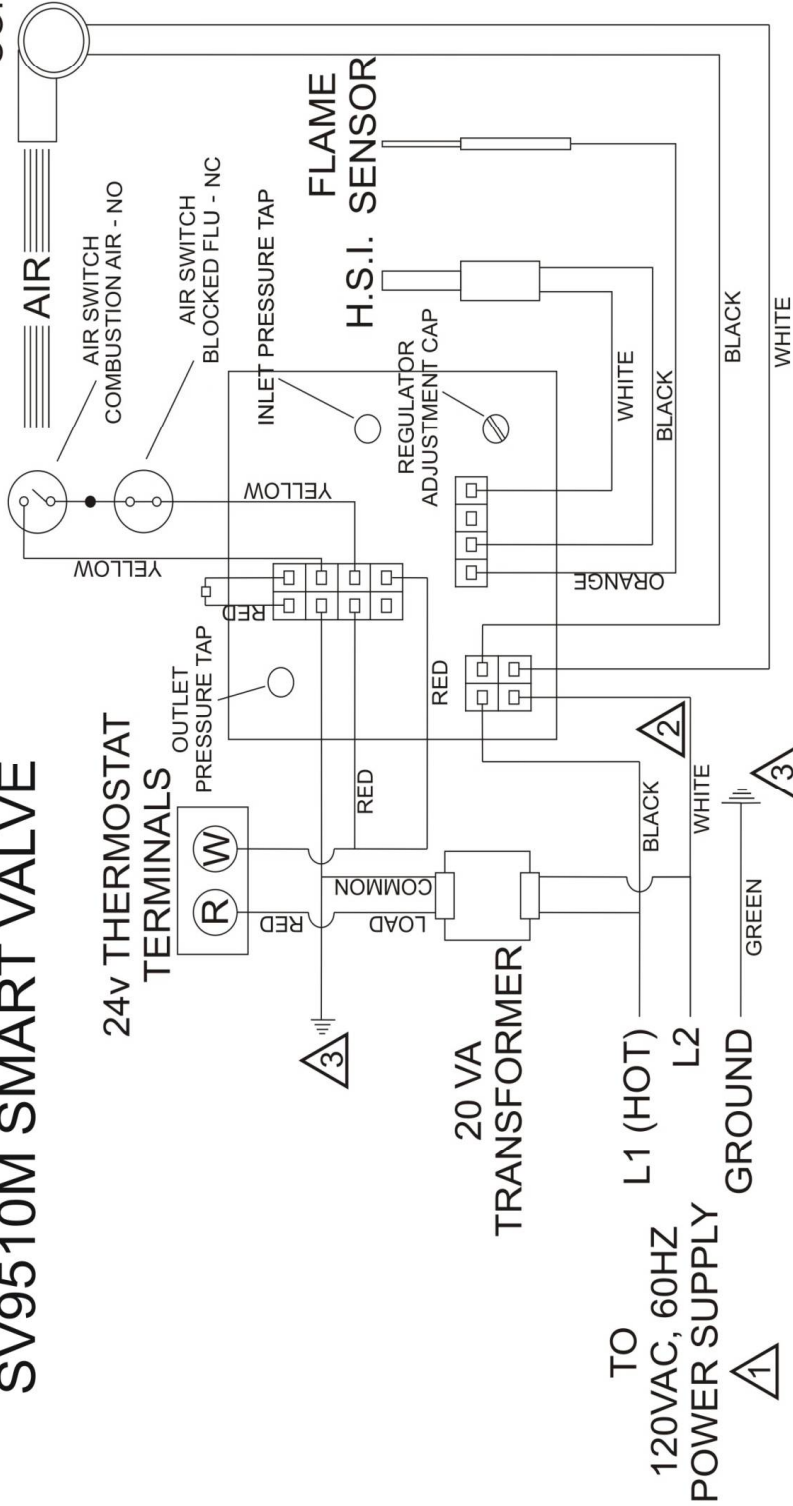

1 120V GROUNDED POWER SUPPLY. PROVIDE DISCONNECT MEANS AND OVERLOAD PROTECTION AS REQUIRED.

2 CONNECT 120V HOT LEAD AS SHOWN

3 APPLIANCE CHASSIS MUST HAVE RELIABLE CONNECTION TO GROUND

HONEYWELL SMARTVALVE

LED STATUS	INDICATES	CHECK/REPAIR
OFF	No power to system control.	<ol style="list-style-type: none"> 1. Line voltage input power at L1 and L2 connectors on Terminal Board. 2. Low voltage (24V) power at 24VAC and COM terminals on Terminal Board. 3. System wiring harness in good condition and securely connected at both ends. 4. Electrical supply is live and functioning properly.
Bright-Dim	Normal Operation. This indication shows whenever the system is powered, unless some abnormal event has occurred.	Not applicable.
2 Flashes	Airflow proving switch remains closed longer than 30 seconds after a call for heat begins. Combustion air blower is not energized until airflow proving switch opens.	<ol style="list-style-type: none"> 1. Airflow proving switch stuck closed. 2. Airflow proving switch miswired or jumpered.
3 Flashes	Airflow proving switch remains open longer than 30 seconds after combustions air blower energized System goes into 5-minute delay period, with combustion air blower off. At the end of the 5-minute delay, another ignition cycle will begin.	<ol style="list-style-type: none"> 1. Ignition system control switch must be in the ON position. 2. Airflow proving switch operation, tubing, and wiring. 3. Obstructions or restrictions in appliance air intake or exhaust flue system that prevent proper combustion air flow.
4 Flashes	Limit string open. Combustion air blower is energized. If control system indicates Electronic Fan Timer, the heat speed circulating air fan will be energized until the limit string resets.	<ol style="list-style-type: none"> 1. Open manual reset or auto reset burner rollout switch. 2. Open high temperature or auxiliary limit switch. 3. Limit and rollout switch wiring in good condition and securely connected.
5 Flashes	Flame signal sensed out of proper sequence. Combustion air blower is energized. If control system indicates Electronic Fan Timer, the heat speed circulation air fan will be energized after the selected heat fan on delay.	Flame at main burner.
6 Flashes	System lockout. After 1 hour lockout reset delay, control will reset and initiate a new ignition sequence if the call for heat is still present.	<ol style="list-style-type: none"> 1. Gas supply off or at too low pressure to operate appliance. 2. Damaged or broken HSI element. 3. Line voltage HOT leadwire not connected to L1 terminal on Terminal Board. 4. Appliance not properly earth grounded. 5. Flame sense rod contaminated or in incorrect position. 6. HSI element located in incorrect position. 7. Hot surface element or flame sense rod wiring in good condition and properly connected.
IF	AND	CHECK / REPAIR
Combustion air blower does not energize.	2 Flash code does not come on 30 seconds after call for heat starts.	<ol style="list-style-type: none"> 1. Combustion air blower wiring 2. Combustion air blower
Combustion air blower does not energize.	2 Flash code does come on 30 seconds after call for heat starts.	<ol style="list-style-type: none"> 1. Airflow proving switch stuck closed. 2. Airflow proving switch miswired or jumpered.
Combustion air blower energized.	3 Flash code does not come on after 30 seconds.	Wait for prepurge time to expire.
3 Flash code comes on 30 seconds after combustion air blower is energized.	Combustions air blower turns off.	<ol style="list-style-type: none"> 1. Ignition system control switch must be in the ON position. 2. Airflow proving switch stuck in open position. 3. Airflow proving switch tubing and wiring. 4. Obstruction or restrictions in appliance air intake or exhaust flue system that prevent proper combustion air flow.
Prepurge time has expired.	HSI Element does not glow red within 10 to 15 seconds.	<ol style="list-style-type: none"> 1. Broken or damaged HSI element. 2. Broken or damaged HSI element leadwires. 3. Failure to power HSI element.
HSI elements is glowing red	No other visible control system action.	Wait for HSI element warm up time to expire.

AB2017 H.S.I. CONTROL MODULE

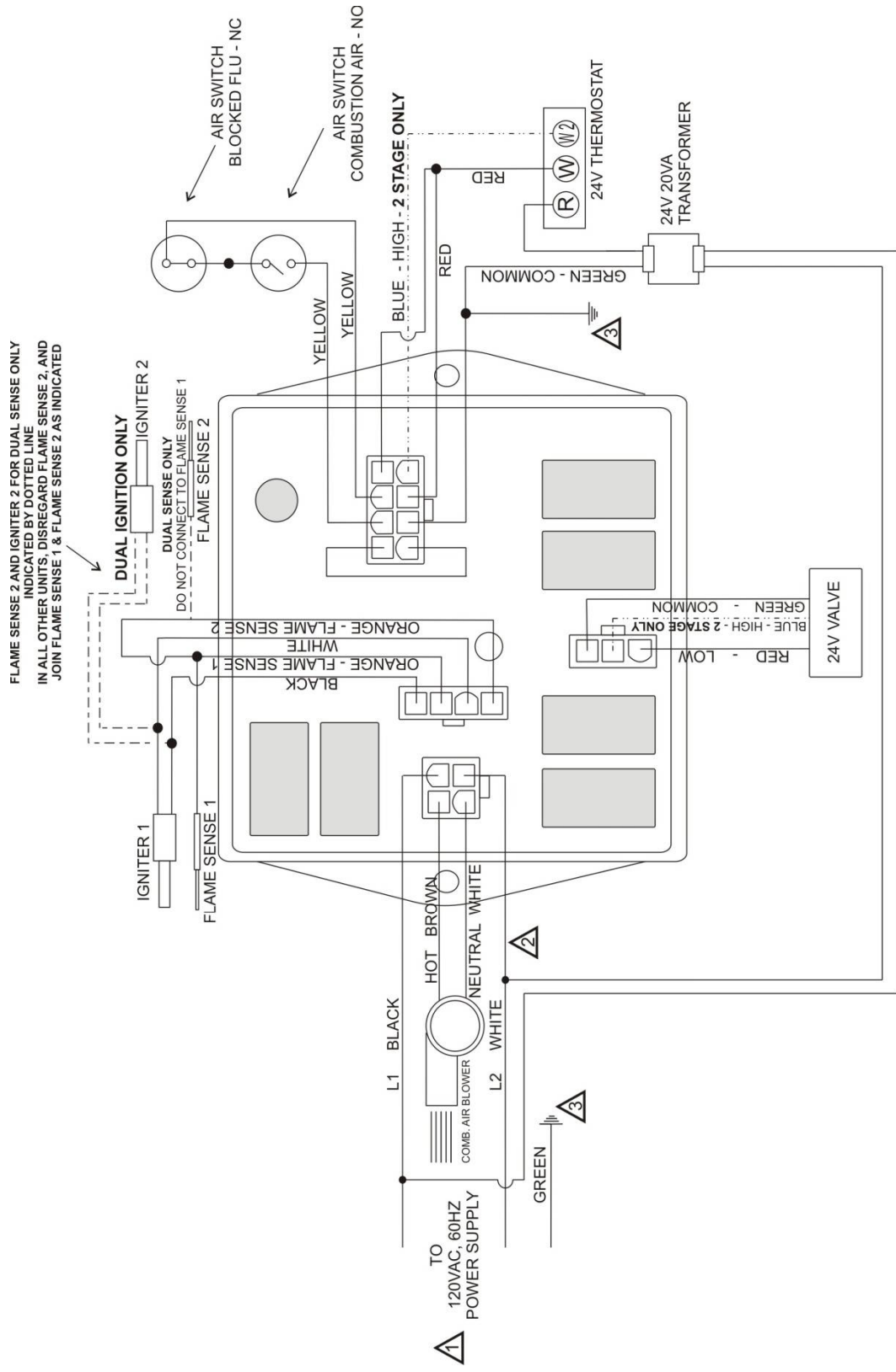

▲ 120V GROUNDED POWER SUPPLY. PROVIDE DISCONNECT MEANS AND OVERLOAD PROTECTION AS REQUIRED.

▲ CONNECT 120V HOT LEAD AS SHOWN

▲ APPLIANCE CHASSIS MUST HAVE RELIABLE CONNECTION TO GROUND

AB2017 CONNECTOR GUIDE

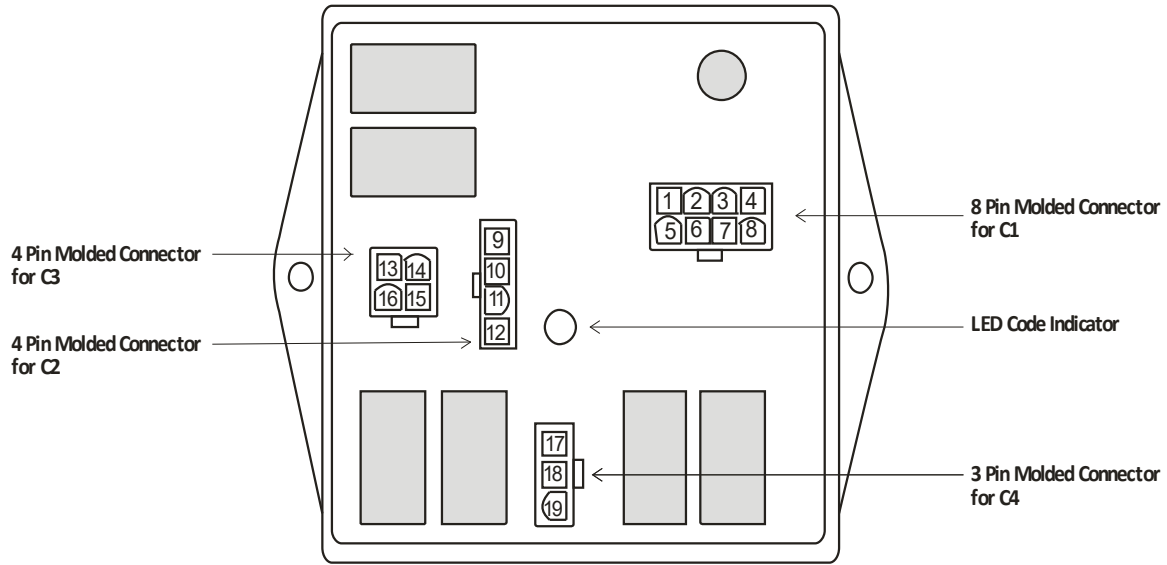

C1	PIN 1	Red	Loop to Pin 5
	PIN 2	Yellow	Common on combustion switch
	PIN 3	Yellow	Common on blocked flue switch
	PIN 4	Red	24V Controller return
	PIN 5	Red	Loop to Pin 1
	PIN 6	Green	Ground to burner
	PIN 7	Red	24 Volt to controller or W1 2-stage controller
	PIN 8	Blue	W2 return from 2-stage controller ONLY (7"wire)
C2	PIN 9	Black	Igniter
	PIN 10	Orange	Flame sensor IMPORTANT: 10 and 12 Loop together for units with single flame sensor. For EZM dual flame sense, 10 and 12 lead to individual flame sensors.
	PIN 11	White	Igniter neutral
	PIN 12	Orange	Flame sensor no. 2 (for dual flame sense, Middleman) IMPORTANT: 10 and 12 Loop together for units with single flame sensor. For EZM dual flame sense, 10 and 12 lead to individual flame sensors. See Middleman Series Installation / Operating instructions.
C3	PIN 13	Brown	Inducer motor
	PIN 14	Black	Line 1 120V
	PIN 15	White	Line 2 neutral
	PIN 16	White	Inducer motor neutral
C4	PIN 17	Green	Valve common
	PIN 18	Blue	Valve 2-stage ONLY (18" wire)
	PIN 19	Red	Valve

AB2017 TROUBLE SHOOTING

LED STATUS	INDICATES	CHECK/REPAIR
OFF	No power to system control.	<ol style="list-style-type: none"> 1. Line voltage input connectors on module. 2. Low voltage 24V and COM connection on module. 3. System wiring harness in good condition and securely connected at both ends. 4. Electrical supply is live and functioning properly.
STEADY ON	Normal Operation. LED is solidly lit when unit is powered, unless some normal abnormal event has occurred.	Not applicable.
1 FLASH	Combustion intake airflow proving switch stuck closed at call for heat.	<ol style="list-style-type: none"> 1. Combustion intake airflow proving switch stuck closed. 2. Combustion intake airflow proving switch mis-wired or jumpered. 3. Combustion intake airflow proving switch operation, tubing, and wiring.
2 FLASHES	Airflow proving switch circuit remained open for 30 seconds after blower energized.	<ol style="list-style-type: none"> 1. Airflow proving switch stuck open. 2. Combustion airflow proving switch mis-wired or jumpered. 3. Blocked flue airflow proving switch stuck open during ignition sequence due to malfunction, blockage, or mis-wiring. 4. Obstructions or restrictions in appliance air intake system that prevent proper combustion air flow. 5. Airflow proving switch operation, tubing, and wiring.
3 FLASHES	Ignition trial lockout. Appliance has failed ignition trial 3 consecutive times. System will reset after 20 minute delay, then initiate a new ignition sequence if the call for heat is still present.	<ol style="list-style-type: none"> 1. Gas supply off or at too low pressure to operate appliance. 2. Damaged or broken HSI element. 3. Line voltage HOT connector not connected to module, or electrical supply failure. 4. Appliance not properly earth grounded. 5. Flame sense rod contaminated or in incorrect position. 6. HSI element located in incorrect position. 7. Hot surface element or flame sense rod wiring in good condition and properly connected. 8. 3 consecutive ignition failures for any cause.
4 FLASHES	Flame sensed out of sequence or internal fault. Module self diagnostics have detected a critical fault in module programming/operation.	Replace ignition module.
IF	AND	CHECK / REPAIR
Combustion air blower does not energize.	1 Flash code does not come on 30 seconds after call for heat starts.	<ol style="list-style-type: none"> 1. Combustion air blower wiring, combustion intake airflow proving switch wiring. 2. Combustion air blower.
Combustion air blower does not energize.	1 Flash code does come on 30 seconds after call for heat starts.	<ol style="list-style-type: none"> 1. Airflow proving switch stuck closed. 2. Airflow proving switch mis-wired or jumpered.
Combustion air blower energized.	2 Flash code does not come on after 30 seconds.	Wait for pre-purge time to expire.
2 Flash code comes on 30 seconds after combustion air blower is energized.	Combustions air blower turns off.	<ol style="list-style-type: none"> 1. Airflow proving switch stuck in open position. 2. Airflow proving switch tubing and wiring. 3. Obstruction or restrictions in appliance air intake or exhaust flue system that prevent proper combustion air flow.
30 second prepurge time has expired.	HSI Element does not glow red within 10 to 15 seconds.	<ol style="list-style-type: none"> 1. Broken or damaged HSI element. 2. Broken or damaged HSI element lead wires. 3. Failure to power HSI element. 4. Check voltage on HSI lead to verify module is sending correct output.
HSI elements is glowing red	No other observable control system action.	1. Flame sensor moisture detected. Wait for HSI element to warm/dry flame sensor. Ignition sequence will commence when no moisture is detected on flame sensor.

**THESE INSTALLATION
INSTRUCTIONS MUST
BE KEPT WITH THE
HEATER**

COMBUSTIBLE MATERIAL STORAGE WARNING SIGN



MAXIMUM STACK HEIGHT UNDER HEATER

Required Clearance
(From Appliance "Below" Clearance) = C _____

Distance From Floor To Lowest Point of Heater
(Measured Post Installation) = D _____

Maximum Stack Height Below Appliance]
(Subtract Dimension C from Dimension D) = H _____

HORIZONTAL MOUNT

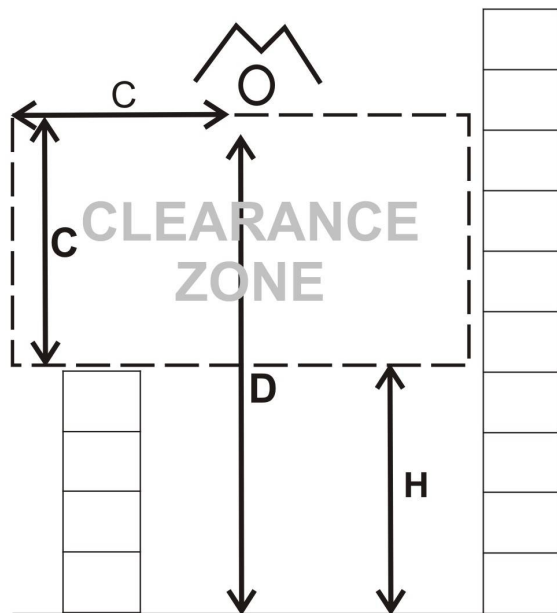

ANGLE MOUNT

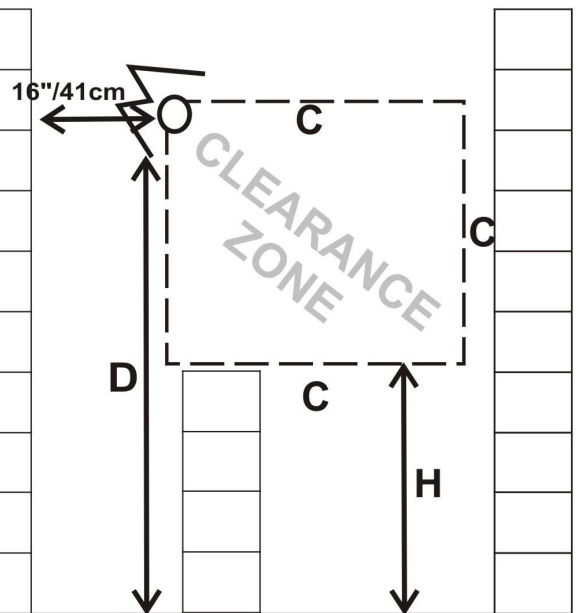

FLOOR

Note: These clearances apply only to stackable combustible materials that may be stacked below/near appliance. Standard clearances to structure for installation purposes are listed on Table 1 and 2 in the installation / operating instructions.

Use a permanent marker to enter values 'C', 'D', and 'H'